

## FEATURES

- **Monolithic 5W Wireless Power Transmitter**
- **AutoResonant™ Switching Frequency Adjusts to Resonant Capacitance and Transmit Coil Inductance\***
- **Transmit Power Automatically Adjusts to Receiver Load\***
- **Input Voltage Range: 3V to 5.5V**
- **Integrated 100mΩ Full Bridge Switches**
- **Multiple Foreign Object Detection Methods**
- Programmable Average Input Current Limit and Monitor
- NTC Input for System/Component Temperature Qualified Power Transfer
- Wide Operating Switching Frequency Range: 50kHz to 250kHz
- Thermally Enhanced 4mm × 5mm QFN 20-Lead Package

## APPLICATIONS

- Hermetically and/or Electrically Insulated Devices
- Military Sensors and Devices
- Medical Equipment
- Industrial Handhelds

## DESCRIPTION

The **LTC®4125** is a simple and high performance monolithic full bridge resonant driver capable of delivering over 5W of power wirelessly to a properly tuned receiver. The device controls the current flow in a series connected transmit coil LC network to create a simple, safe and versatile wireless power transmitter.

The LTC4125 automatically adjusts its driving frequency to match the LC network resonant frequency. This AutoResonant switching allows the device to deliver maximum power from a low voltage input supply (3V to 5.5V) to a tuned receiver. To optimize system efficiency, the LTC4125 employs a periodic transmit power search and adjusts the transmission power based on the receiver load requirements. The device stops delivering power during a fault condition, or if a foreign object is detected.

The LTC4125 also includes a programmable maximum average input current limit and an NTC input as additional means for foreign object and overload protection. The LTC4125 is available in a 20-lead low profile (0.75mm) 4mm × 5mm QFN package.

LT, LT, LTC, LTM, Linear Technology and the Linear logo are registered trademarks and AutoResonant is a trademark of Linear Technology Corporation. All other trademarks are the property of their respective owners. Protected by U.S. Patents, including 9041254.  
 \*The AutoResonant and Auto Load Detect features use patent pending circuits and algorithms.

## TYPICAL APPLICATION

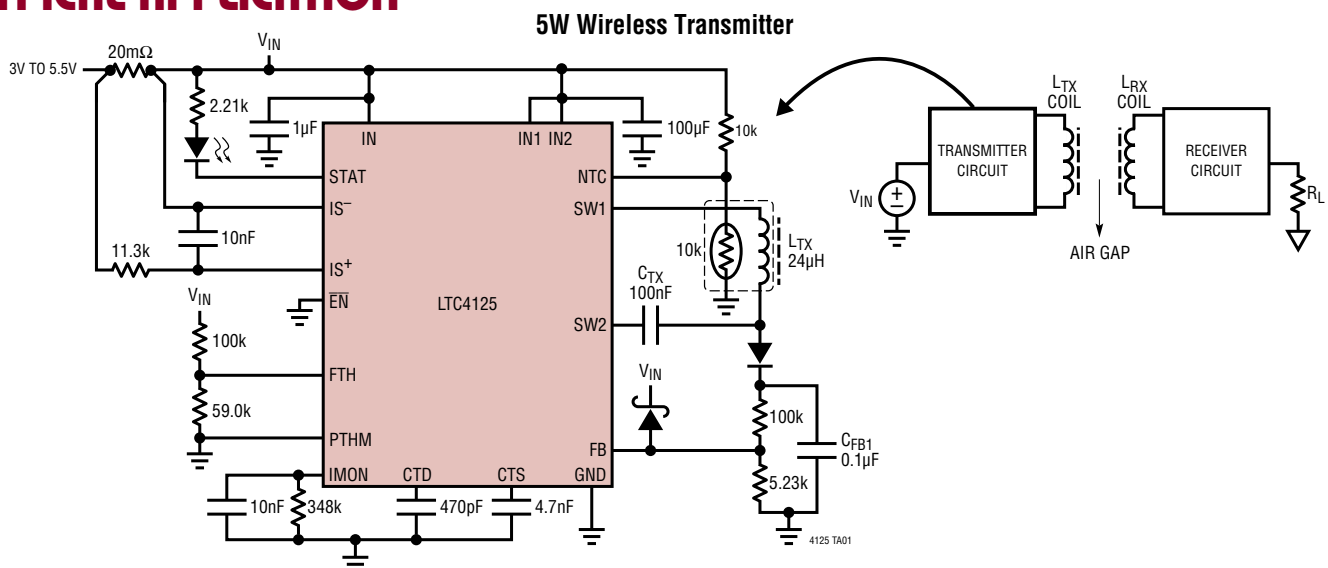

# LTC4125

## ABSOLUTE MAXIMUM RATINGS

(Note 1)

|                                      |   |
|--------------------------------------|---|
| IN, IS <sup>-</sup> , CTD .....      | -0.3V to 6V   |
| IN1, IN2, IS <sup>+</sup> .....      | -0.3V to V <sub>IN</sub> + 0.3V   |
| DTH, FTH, PTHM, FB .....             | -0.3V to V <sub>IN</sub> + 0.3V   |
| NTC, EN, PTH1, PTH2, CTS .....       | -0.3V to V <sub>IN</sub> + 0.3V   |
| IMON .....                           | -0.3V to MIN(V <sub>IN</sub> , V <sub>IS+</sub> , V <sub>IS-</sub> ) + 0.3V |
| STAT .....                           | -0.3V to V <sub>IN</sub> + 0.3V   |
| STAT .....                           | -1mA to 2mA   |
| Operating Junction Temperature Range |   |
| (Note 2) .....                       | -40°C to 125°C  |
| Storage Temperature Range .....      | -65°C to 150°C  |

## PIN CONFIGURATION

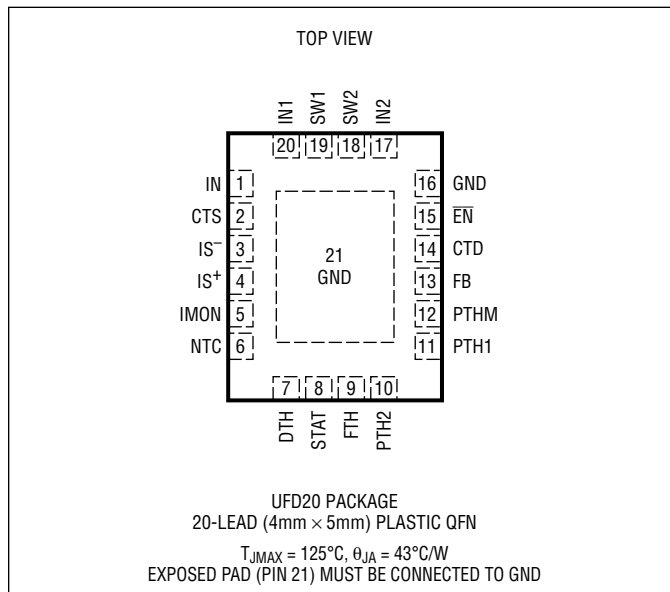

## ORDER INFORMATION

| LEAD FREE FINISH | TAPE AND REEL     | PART MARKING | PACKAGE DESCRIPTION             | TEMPERATURE RANGE |
|------------------|-------------------|--------------|---------------------------------|-------------------|
| LTC4125EUFD#PBF  | LTC4125EUFD#TRPBF | 4125         | 20-Lead (4mm × 5mm) Plastic QFN | -40°C to 125°C    |
| LTC4125IUFD#PBF  | LTC4125IUFD#TRPBF | 4125         | 20-Lead (4mm × 5mm) Plastic QFN | -40°C to 125°C    |

Consult LTC Marketing for parts specified with wider operating temperature ranges.

For more information on lead free part marking, go to: <http://www.linear.com/leadfree/>

For more information on tape and reel specifications, go to: <http://www.linear.com/tapeandreeel/>. Some packages are available in 500 unit reels through designated sales channels with #TRMPBF suffix.

## ELECTRICAL CHARACTERISTICS

The ● denotes the specifications which apply over the specified operating junction temperature range, otherwise specifications are at  $T_A = 25^\circ\text{C}$ .  $V_{IN} = V_{IN1} = V_{IN2} = 5\text{V}$  unless otherwise noted (Notes 2, 3).

| SYMBOL   | PARAMETER  | CONDITIONS   |   | MIN             | TYP      | MAX             | UNITS               |
|--|--|--|---|-----------------|----------|-----------------|---------------------|
|  | Input Supply Operating Range   | $V_{IN} = V_{IN1} = V_{IN2}$   | ● | 3               |          | 5.5             | V                   |
|  | Input Supply Quiescent Current<br>At IN pin<br>At IN1, IN2 pin                   | SW1 and SW2 Open<br>$\overline{EN} = 5\text{V}$  |   |                 | 1<br>50  | 2<br>150        | mA<br>$\mu\text{A}$ |
| <b>Enable Pin</b>                                |  |  |   |                 |          |                 |                     |
|  | $\overline{EN}$ Leakage Current  | $V_{\overline{EN}} = 5\text{V}$  | ● | 0.2             | 0.5      | 1.2             | $\mu\text{A}$       |
|  | $\overline{EN}$ Falling Threshold  | $V_{\overline{EN}}$ Falling  |   |                 | 1.20     |                 | V                   |
|  | $\overline{EN}$ Hysteresis   |  |   |                 | 16       |                 | mV                  |
| <b>Search Delay Oscillator Pins</b>              |  |  |   |                 |          |                 |                     |
| $I_{CTS,PU}$                                     | CTS Pull-Up Current  | $V_{CTS} = 0\text{V}$  |   |                 | -10      |                 | $\mu\text{A}$       |
| $I_{CTS,PD}$                                     | CTS Pull-Down Current  | $V_{CTS} = 2\text{V}$  |   |                 | 10       |                 | $\mu\text{A}$       |
|  | CTS Pin Frequency  | $C_{CTS} = 4.7\text{nF}$   |   | 1.0             | 1.7      | 2.4             | kHz                 |
|  | CTS Threshold for AutoResonant Disable   |  | ● | 1.8             | 2.3      | 2.8             | V                   |
| $I_{CTD,PU}$                                     | CTD Pull-Up Current  | $V_{CTD} = 0\text{V}$  |   |                 | -10      |                 | $\mu\text{A}$       |
| $I_{CTD,PD}$                                     | CTD Pull-Down Current  | $V_{CTD} = 2\text{V}$  |   |                 | 10       |                 | $\mu\text{A}$       |
|  | CTD Pin Frequency  | $C_{CTD} = 470\text{pF}$   |   | 10              | 17       | 24              | kHz                 |
| <b>Resonant Driver and Pulse Width Modulator</b> |  |  |   |                 |          |                 |                     |
|  | Operating Frequency Range  |  |   | 50              |          | 250             | kHz                 |
| $R_{A,B,C,D}$                                    | Switch On Resistances  | MOSFETs A, B, C and D (Block Diagram)  |   |                 | 150      |                 | $\text{m}\Omega$    |
|  | Switch Pins Minimum On Time  | SW1, SW2   |   |                 | 150      |                 | ns                  |
|  | Minimum PTH Voltage for Switching  |  |   |                 | 35       |                 | mV                  |
|  | PTH Voltage to Pulse Width Gain normalized to the LC natural frequency ( $f_n$ ) | SW1 On Time $\cdot f_n / \Delta V_{PTH1}$ ,<br>SW2 On Time $\cdot f_n / \Delta V_{PTH2}$ |   |                 | 0.24     |                 | $\text{V}^{-1}$     |
|  | PTH Pull Up Current when Overdriving   | $V_{PTH1} = V_{PTH2} = 0\text{V}$  | ● | -20             | -10      | -5              | $\mu\text{A}$       |
|  | PTH Pull Down Current when Overdriving   | $V_{PTH1} = V_{PTH2} = 5\text{V}$  | ● | 10              | 20       | 40              | $\mu\text{A}$       |
| <b>Auto Load Detection</b>                       |  |  |   |                 |          |                 |                     |
|  | $V_{PTH}$ Step Size during Auto Load Detection Search                            |  |   |                 | 75       |                 | mV                  |
|  | Delay Time between Optimum Point Search  | $C_{CTD} = 470\text{pF}$   |   |                 | 3.7      |                 | s                   |
|  | Optimum Point Search Duration  | $C_{CTS} = 470\text{pF}$ (Figure 13)   |   |                 | 40       |                 | ms                  |
|  | FB Pin Leakage Current   | $V_{FB} = 5\text{V}$   | ● | 0.2             | 0.5      | 1.2             | $\mu\text{A}$       |
|  | FB Over-Range Rising Threshold   | $V_{FB}$ Rising  | ● | $V_{IN} - 0.04$ | $V_{IN}$ | $V_{IN} + 0.04$ | V                   |
|  | FB Over-Range Threshold Hysteresis   |  |   |                 | 40       |                 | mV                  |
|  | PTHM Pin Leakage Current   | $V_{PTHM} = 5\text{V}$   | ● | 0.2             | 0.5      | 1.2             | $\mu\text{A}$       |
|  | PTHM Pin Common Mode Voltage Range   |  |   | 0               |          | 5               | V                   |
|  | FTH Pin Leakage Current  | $V_{FTH} = 0\text{V}$  | ● | -1.2            | -0.5     | -0.2            | $\mu\text{A}$       |
|  | FTH Voltage to Frequency Gain  |  |   |                 | 64       |                 | kHz/V               |
|  | DTH Pin Leakage Current  | $V_{DTH} = 0\text{V}$  | ● | -1.2            | -0.5     | -0.2            | $\mu\text{A}$       |

## ELECTRICAL CHARACTERISTICS

The ● denotes the specifications which apply over the specified operating junction temperature range, otherwise specifications are at  $T_A = 25^\circ\text{C}$ .  $V_{IN} = V_{IN1} = V_{IN2} = 5\text{V}$  unless otherwise noted (Notes 2, 3).

| SYMBOL                                    | PARAMETER  | CONDITIONS  |   | MIN          | TYP   | MAX        | UNITS                        |
|---|--|---|---|--------------|-------|------------|------------------------------|
| <b>Input Current Limit and Monitoring</b> |  |   |   |              |       |            |                              |
| $V_{IS+,IS-}$                             | Sense Voltage Offset   |   | ● | -500<br>-1.5 |       | 500<br>1.5 | $\mu\text{V}$<br>$\text{mV}$ |
|   | $IS^+$ Pin Current   | $V_{IS+} = 5\text{V}$ , $V_{IS+,IS-} = -50\text{mV}$              |   | -100         |       | 100        | $\text{nA}$                  |
|   | $IS^-$ Pin Current   | $V_{IS-} = V_{IS+} = 5\text{V}$                                   |   |              | 15    |            | $\mu\text{A}$                |
|   | IMON Pin Leakage Current   | $V_{IS+,IS-} = -50\text{mV}$ , $V_{IMON} = 0\text{V} - 5\text{V}$ |   | -100         |       | 100        | $\text{nA}$                  |
| $V_{ITH}$                                 | Input Current Comparator Threshold at IMON during Search           | $V_{IMON}$ Rising   | ● | 0.785        | 0.800 | 0.815      | V                            |
| $V_{ILIM}$                                | Input Current Limit Comparator Threshold at IMON during Delay Time | $V_{IMON}$ Rising   | ● | 1.175        | 1.200 | 1.225      | V                            |
|   | Input Current Limit Comparator Hysteresis                          |   |   |              | 40    |            | $\text{mV}$                  |
| <b>Thermistor Input</b>                   |  |   |   |              |       |            |                              |
|   | NTC Hot Threshold  | $V_{NTC}$ Falling, % of $V_{IN}$                                  | ● | 33           | 35    | 37         | % $V_{IN}$                   |
|   | NTC Thresholds Hysteresis  | % of $V_{IN}$   |   |              | 5     |            | % $V_{IN}$                   |
|   | NTC Open Circuit Voltage   | % of $V_{IN}$   | ● | 48           | 50    | 52         | % $V_{IN}$                   |
|   | NTC Open Circuit Input Resistance                                  |   |   |              | 300   |            | $\text{k}\Omega$             |
| <b>Open Drain Status Pin</b>              |  |   |   |              |       |            |                              |
|   | STAT Pin Leakage Current   | $V_{STAT} = 5\text{V}$  |   | -1           |       | 1          | $\mu\text{A}$                |
|   | STAT Pin Output Voltage Low  | $I_{STAT} = 1\text{mA}$   | ● |              |       | 0.4        | V                            |

**Note 1:** Stresses beyond those listed under Absolute Maximum Ratings may cause permanent damage to the device. Exposure to any Absolute Maximum Rating condition for extended periods may affect device reliability and lifetime.

**Note 2:** The LTC4125 is tested under conditions such that  $T_J \approx T_A$ . The LTC4125E is guaranteed to meet specifications from  $0^\circ\text{C}$  to  $85^\circ\text{C}$  junction temperature. Specifications over the  $-40^\circ\text{C}$  to  $125^\circ\text{C}$  operating junction temperature are assured by design, characterization and correlation with statistical process controls. The LTC4125I is guaranteed over the full  $-40^\circ\text{C}$  to  $125^\circ\text{C}$  operating junction temperature range. The junction temperature ( $T_J$ , in  $^\circ\text{C}$ ) is calculated from the ambient temperature ( $T_A$ , in  $^\circ\text{C}$ ) and power dissipation ( $P_D$ , in Watts) according to the following formula:

$$T_J = T_A + (P_D \cdot \theta_{JA}), \text{ where } \theta_{JA} \text{ (in } ^\circ\text{C/W) is the package thermal impedance.}$$

Note that the maximum ambient temperature consistent with these specifications is determined by specific operating conditions in conjunction with board layout, the rated package thermal impedance and other environmental factors. This IC includes over temperature protection that is intended to protect the device during momentary SW MOSFETs over current situation. Junction temperature will exceed  $125^\circ\text{C}$  when over temperature protection is active. Continuous operation above the specified maximum operating junction temperature may impair device reliability.

**Note 3:** All currents into pins are positive; all voltages are referenced to GND unless otherwise noted.

**Note 4:** This IC includes overtemperature protection that is intended to protect the device. Junction temperature will exceed  $125^\circ\text{C}$  when overtemperature protection is active. Continuous operation above the specified maximum operating junction temperature will reduce lifetime.

**TYPICAL PERFORMANCE CHARACTERISTICS**  $T_A = 25^\circ\text{C}$ , unless otherwise noted.

**Supply Quiescent Current at IN, IN1 and IN2 Over Temperature**

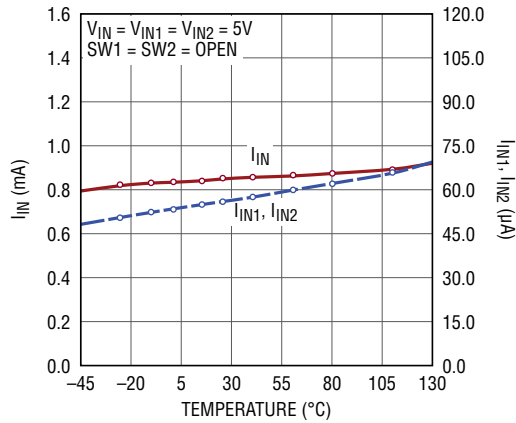

4125 G01

**EN Threshold Over Temperature**

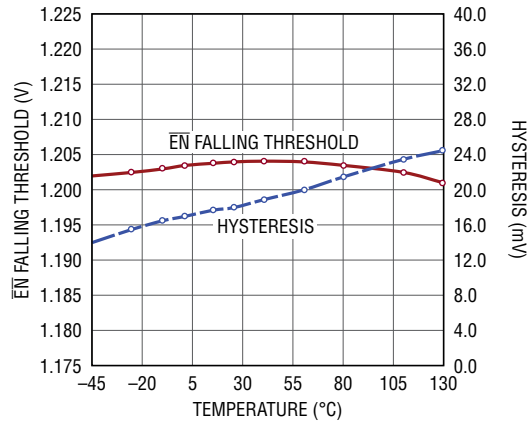

4125 G02

**$C_{TS}$ ,  $C_{TD}$  Pin Frequency and Search Delay Time Over Temperature**

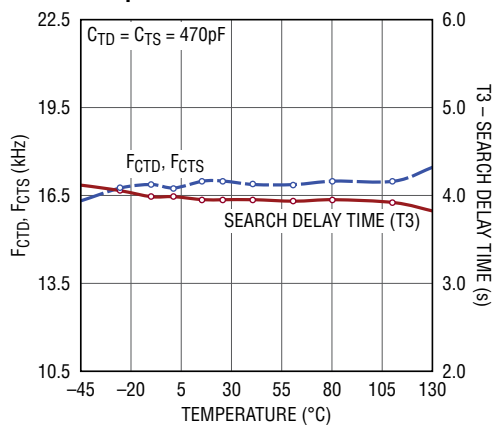

4125 G03

**Switch Resistances Over Temperature**

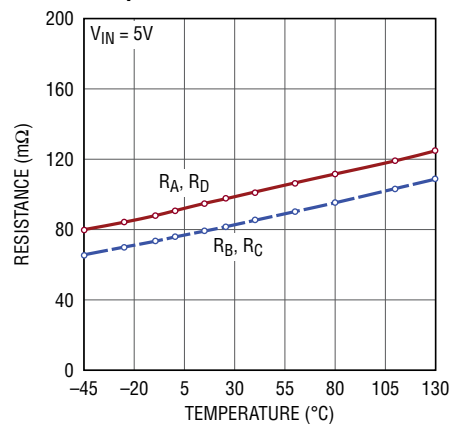

4125 G04

**$V_{IS+}$ ,  $V_{IS-}$  Sense Amplifier Offset Over Temperature**

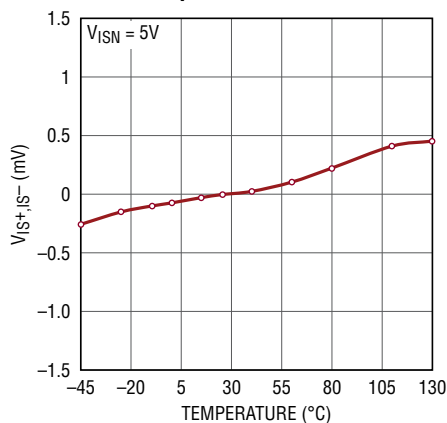

4125 G05

**Input Current Threshold and Limit Over Temperature**

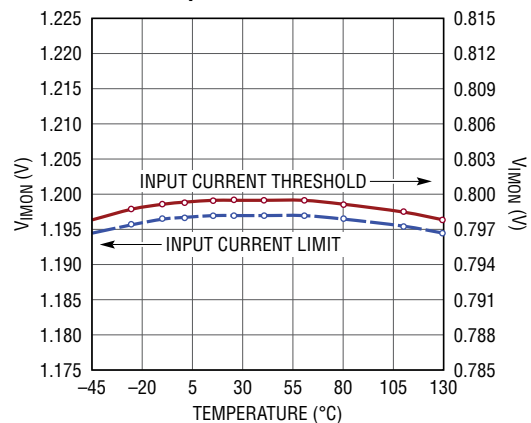

4125 G06

## PIN FUNCTIONS

**IN (Pin 1):** Input Supply Voltage: 3V to 5.5V. Supplies power to the internal circuitry. A local 1 $\mu$ F bypass capacitor to GND is recommended on this pin.

**CTS (Pin 2):** Transmit Power Search Settling Time Capacitor. Attach a capacitor from the CTS pin to GND to program the transmit power search settling time. Recommended settling times are typically between 1ms and 20ms. See Applications Information for programming instructions. While not recommended, short to IN to disable the AutoResonant driver.

**IS<sup>-</sup> (Pin 3):** Input Current Sense Negative Input. Connect a current sense resistor ( $R_{IS}$ ) between the supply voltage and IS<sup>-</sup> using Kelvin Sense practices to monitor the input supply current. Tie this pin to the IS<sup>+</sup> pin if no input current monitoring is desired. Refer to the Applications Information section for complete details.

**IS<sup>+</sup> (Pin 4):** Input Current Sense Positive Input. Connect this pin via an input current sense gain resistor ( $R_{IN}$ ) to the supply voltage connected to the  $R_{IS}$  sense resistor. This pin sinks a current proportional to the voltage across the sense resistor ( $R_{IS}$ ) which is used to generate the IMON output (see Block Diagram):

$$I_{IS^+} = \frac{I_{RIS} \cdot R_{IS}}{R_{IN}}$$

Tie this pin to the IS<sup>-</sup> pin if no input current monitoring is desired. Refer to the Applications Information section for complete details.

**IMON (Pin 5):** Input Current Monitor. The IMON pin sources a current that is proportional to the sense voltage across the sense resistor ( $R_{IS}$ ). With an output gain resistor ( $R_{IMON}$ ), the voltage on this pin is expressed as follows and corresponds directly to the input current (see Block Diagram):

$$V_{IMON} = \frac{I_{RIS} \cdot R_{IS}}{R_{IN}} \cdot R_{IMON} = \frac{R_{IMON}}{R_{IN}} \cdot \Delta V_{RIS}$$

Connect an appropriate capacitor in parallel with  $R_{IMON}$  on this pin to obtain a time-averaged voltage representation of the input current (see Applications Information for more details). If the voltage on this pin reaches 0.80V ( $V_{ITH}$ , typ)

during a power search, an internal comparator indicates that the input current threshold has been exceeded, and the search is paused at this state until the next search interval. The programmed input current threshold is determined using the following formula:

$$I_{TH} = \frac{R_{IN}}{R_{IMON}} \cdot \frac{V_{ITH}}{R_{IS}} = \frac{R_{IN}}{R_{IMON}} \cdot \frac{0.80V}{R_{IS}}$$

If the voltage on the IMON pin exceeds 1.20V ( $V_{LIM}$ , typ) at any point during the pause/delay time between the search intervals, an internal comparator indicates that input current limit has been exceeded, the power delivery is immediately stopped, and a new search interval is initiated. The programmed input current limit is determined using the following formula:

$$I_{LIM} = \frac{R_{IN}}{R_{IMON}} \cdot \frac{V_{LIM}}{R_{IS}} = \frac{R_{IN}}{R_{IMON}} \cdot \frac{1.20V}{R_{IS}}$$

Short this pin to GND to disable the input current monitor feature.

**NTC (Pin 6):** Thermistor Input. Connect a thermistor from NTC to GND, and a corresponding resistor from IN to NTC. The voltage level on this pin determines if the thermistor temperature is within an acceptable range. The power delivery is stopped if the thermistor indicates a temperature that is too hot. This feature may be used to detect the presence of a foreign metal object or other transmission fault. Once the temperature returns to the safe region, power delivery resumes. Refer to the Applications Information section for suggested usage. Leave this pin open to disable the temperature qualified power delivery feature.

**DTH (Pin 7):** Delta FB Threshold Input. This pin is used to adjust the minimum detected power step size in the transmit power search to find the optimum transmitter power operating point. The default setting (pin shorted to IN) ensures proper operation in most systems. However, in very low power or very weakly coupled systems a smaller step size may be desired. Connect this pin to the center tap point of a resistor divider between IN and GND. Please refer to the Operation and Applications Information sections for more details.

## PIN FUNCTIONS

**STAT (Pin 8):** Open Drain Status Pin. This pin pulls low when the part is delivering power. When connected to an LED, this pin provides a visual indicator that the LTC4125 is delivering power to a valid resonant receiver. The STAT pin is high-impedance during a fault condition or if no receiver is detected during the most recent transmit power sweep.

**FTH (Pin 9):** Frequency Threshold Input. This pin is used to program the primary foreign object detection method. Connect this pin to the center tap point of a resistor divider between IN and GND to set the maximum expected transmit LC resonant frequency value (see Applications Information for programming details). A resonant driving frequency exceeding the programmed value indicates the presence of a large conductive object in the field space generated by the transmit coil. Such a condition reduces the apparent inductance of the LC tank resulting in a higher driving frequency. Transmitting into a foreign conductive object may result in TX power overload and/or excessive heating of the foreign object. If a frequency fault is detected, power delivery will immediately stop until the next transmit power search.

**PTH2 (Pin 10):** Pulse Width Threshold Two Pin. The positive pulse width waveform on the SW2 pin is proportional to the voltage on this pin.

**PTH1 (Pin 11):** Pulse Width Threshold One Pin. The positive pulse width waveform on the SW1 pin is proportional to the voltage on this pin.

**PTHM (Pin 12):** Minimum Driver Pulse Width Input. The voltage value on this pin determines the minimum driver pulse width value used in the transmit power search. The driver pulse width corresponds to transmit power. Shorting this pin to GND sets the pulse width of the first step in the search to 1/32 of the natural period of the transmitting LC tank. A faster transmit power search can be implemented when it is known that low transmit power (corresponding to the 1/32 period pulse width) is not sufficient to meet the requirements of the receiver load. Connect the pin to the center tap point of a resistor divider between IN and GND (See Applications Information) to program a larger minimum pulse width.

**FB (Pin 13):** Resonance Feedback Voltage. Connect this pin to the center tap point of a resistor divider between

the rectified peak voltage generated in the series LC tank and GND (see Applications Information). The voltage on the FB pin is monitored during the transmit power search to determine when the load requirements of the receiver have been met or exceeded. Short this pin to GND to disable the internal auto load detection feature.

**CTD (Pin 14):** Transmit Power Search Delay Time Capacitor. Attach a capacitor from the CTD pin to GND to program the delay time between each cycle of an optimum transmit power search. Recommended delay times are typically 1s or greater. See Applications Information for programming instructions. Short to GND to stop search after the first cycle or leave open to default to a minimum delay time (~20ms) between search intervals.

**EN (Pin 15):** Enable Input Pin. Drive this pin above 1.22V (typ) to disable the AutoResonant driver. The SW1 and SW2 pins default low when driver is disabled. Leave the EN pin open or shorted to GND when disable function is not used.

**GND (Pin 16, Exposed Pad Pin 21):** Device Ground. Connect this ground pin to a suitable PCB copper ground plane for proper electrical operation and rated thermal performance.

**IN2 (Pin 17):** Input Supply Voltage: 3V to 5.5V. Supplies power to the second half of the full bridge drivers. A local 47μF bypass capacitor to GND is recommended on this pin.

**SW2 (Pin 18):** Switch 2 Pin. This pin is the center node of the second half of the full bridge switches. Connect a series LC network between this pin and the SW1 pin for full bridge operation.

**SW1 (Pin 19):** Switch 1 Pin. This pin is the center node of the first half of the full bridge switches. Connect a series LC network between this pin and the SW2 pin for full bridge operation. Connect a series LC network between this pin and GND when only half bridge operation is desired. Maximum transmit power available is higher with full bridge operation.

**IN1 (Pin 20):** Input Supply Voltage: 3V to 5.5V. Supplies power to the first half of the full bridge drivers. A local 47μF bypass capacitor to GND is recommended on this pin.

**FUNCTIONAL BLOCK DIAGRAM**

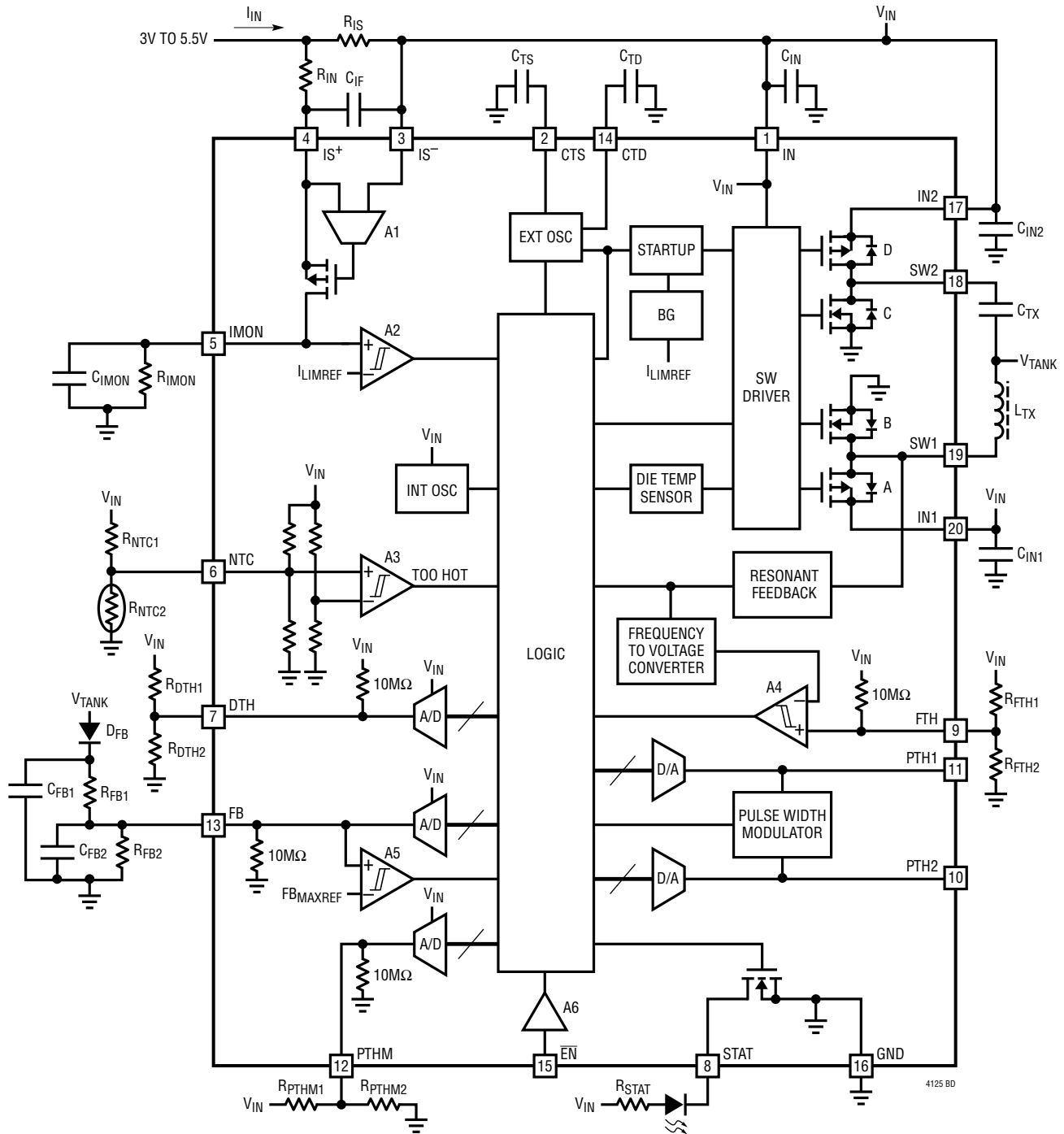



## OPERATION

### INTRODUCTION

A wireless power system is composed of two parts separated by an air gap: transmit circuitry with a transmit coil, and receive circuitry with a receive coil. The LTC4125 is the power controller for a simple but versatile wireless power transmitter. The LTC4125 enhances a basic wireless power transmitter by providing three key features: an AutoResonant function that maximizes available receiver power, an Optimum Power Search algorithm that maximizes overall wireless power system efficiency and foreign object detection to ensure safe and reliable operation when working in the presence of conductive foreign objects. In order to understand these features, an overview of wireless power systems is required.

In a typical wireless power system, an AC magnetic field is generated by a transmit coil which then induces an AC current in the receive coil—like a typical transformer system. The main difference between a transformer system and a wireless power system is that an air gap (or other non-magnetic material gap) separates the primary (transmitter) and secondary (receiver). Furthermore, the coupling between the transmit and the receive coils is typically very low. Whereas a coupling of 0.95 to 1 is common in a transformer system, the coupling coefficient in the wireless power system varies from 0.8 to as low as 0.05.

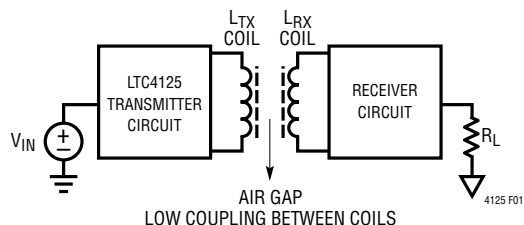

Figure 1. Typical Wireless Power System Setup

In order to induce enough AC current in the receive coil with such low coupling, a strong magnetic field is needed. Since the magnetic field generated by the transmit coil is proportional to the current flowing in the coil, a large AC current needs to be generated in the transmit coil.

There are various ways of producing a large AC current in an inductor from a DC voltage. The LTC4125 is designed to employ one of the simplest and most efficient methods using a series LC resonant circuit.

### SERIES RLC

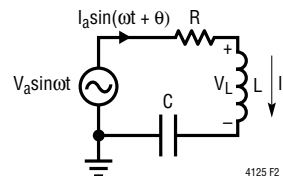

Figure 2. Simple Series Resonant RLC Circuit

Figure 2 shows a simple series resonant circuit. When driven with a sinusoid voltage at the resonant frequency the impedance of the inductor and the capacitor cancels leaving a pure resistance  $R$ . The resonant frequency can be calculated as:

$$f_n = \frac{1}{2\pi\sqrt{LC}}$$

Therefore at resonance the amplitude of current developed in the inductor is simply:

$$I_a = \frac{V_a}{R}$$

Notice that at resonance, with a low enough  $R$  value, a significant amount of inductor current can be generated. Furthermore, the inductor voltage is proportional to the driving voltage:

$$V_L = I_a \cdot \omega_n L = V_a \cdot \frac{\omega_n L}{R} = QV_a$$

where  $Q$  is the familiar quality factor of the series tank.

The LTC4125 enables a series LC to be driven at exactly its resonant frequency with ease. It uses a patent pending AutoResonant method to automatically detect the resonant frequency of the series LC connected to its switch pins and drive it at that frequency.

## OPERATION

### AUTORESONANT DRIVE

Consider the series resonant structure in Figure 2. If a square wave voltage source is used instead of a sinusoidal voltage source, the analysis for the rest of the circuit does not change significantly assuming the values of R, L and C result in a high quality factor (Q greater than 10). The frequency selectivity of a high Q circuit ensures that primarily the fundamental component of the square wave affects the voltage and current waveforms across the inductor and the capacitor (Figure 3).

At start up, the LTC4125 will drive the LC tank with a 50% duty cycle square wave at 2.5kHz. When current is developed in the LC tank, the LTC4125 detects this condition, and adjusts the frequency of the drive voltage accordingly.

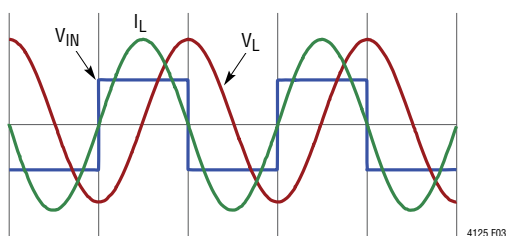

**Figure 3. LC Tank Voltage and Current Waveforms with Square Wave Input at the Resonant Frequency**

AutoResonant Drive ensures that the voltage at each SW pin is always in phase with the current into the pin (refer to the Block Diagram: when current is flowing from SW1 to SW2, switch A and C are on while D and B are off; and vice versa in reverse). Locking the driving frequency cycle by cycle with this method ensures that LTC4125 always drives the external LC network at its resonant frequency. This is true even with continuously changing variables that affect the resonant frequency of the LC tank such as temperature and the reflected impedance of a nearby receiver.

### OPTIMUM POWER SEARCH BACKGROUND

In a wireless power system, the magnetic field at the transmit coil needs to be strong enough to ensure that sufficient power can be delivered to the receiver load at the worst coupling condition. However, under best case

coupling conditions, such a strong magnetic field will be inefficient and may damage the receiver. Given dissipative elements in the transmit circuitry, transmitting any more power than necessary will result in reduced efficiency. Therefore it is desirable to adjust the strength of the magnetic field generated by the transmit coil such that just enough power is available to support the load at the receive coil—the optimum transmit power point.

Aside from efficiency, there is also a matter of safety. When a conductive object is placed in the magnetic field generated by the transmit coil, eddy current will be generated in the object. These eddy currents generate heat due to the object resistance. This heating is undesirable for safety reasons, especially in higher power applications.

LTC4125 has features that address these two issues: improved efficiency across all coupling conditions and foreign object detection/protection that enhances safe operations.

### OPTIMUM POWER SEARCH OPERATION

The Optimum Power Search takes advantage of the fact that transmit power can be adjusted by varying the pulse width of the full bridge driver. AutoResonant Drive continues to operate as pulse width is varied to control the amount of transmit coil current. Figure 4 shows tank current and voltage waveforms using a drive pulse width resulting in a duty cycle less than 50%.

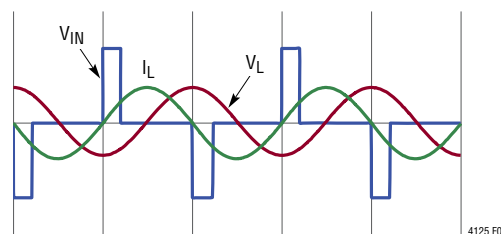
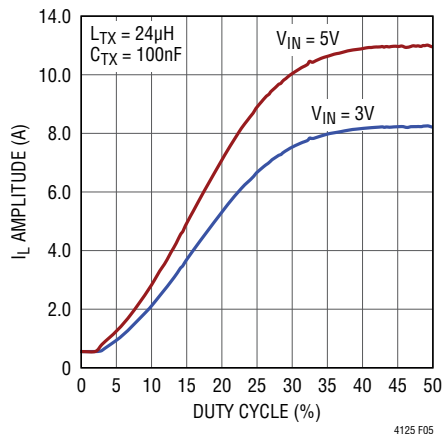

**Figure 4. LC Tank Voltage and Current Waveforms with Square Wave Input at Less Than 50% Duty Cycle for a Series RLC Circuit**

The drive duty cycle is proportional to pulse width. Figure 5 shows how tank current increases as duty cycle is varied from 0% to 50%. Note that controlling the amplitude of transmit coil current is equivalent to controlling the voltage amplitude across the coil at a particular frequency.

## OPERATION

By adjusting the pulse width of the full bridge driver, the LTC4125 can control both coil current and voltage.



**Figure 5. Typical Amplitude of Current Generated at the Transmit Coil versus Duty Cycle with the AutoResonant Method**

The Optimum Power Search works by performing a step-wise linear ramp of transmit power at regular intervals to detect the presence or absence of a valid receiver, the presence or absence of a fault condition, and to optimize the transmit power delivery. The linear ramp of transmit power is accomplished through pulse width modulation (PWM) of the full bridge driver one step at a time. Using the FB pin, the LTC4125 monitors the magnitude of the transmit LC tank voltage at each step.

To optimize transmit power delivery, the LTC4125 looks for a large change in peak tank voltage (up or down) from one step to the next (see Applications Information section). This indicates that the transmit power required to satisfy the receiver load has been met or exceeded. Once the LTC4125 detects a sufficiently large change in tank voltage the search stops, having found a valid exit condition. The transmit power is held at this level until the next search interval.

If the input current exceeds the input current threshold ( $I_{TH}$ ) during the power search, then the search stops and the pulse width is held until the next search interval. This is also a valid exit condition. When any valid exit condition is found, the STAT pin is pulled low to indicate that power is being delivered to the RX coil.

If any of the following thresholds are exceeded during power search, then the search stops and the pulse width is

reduced to zero: the temperature threshold as determined by the NTC input, the maximum tank voltage threshold, the internal die over temperature threshold, or the frequency threshold (foreign object) and the input current limit ( $I_{LIM}$ ). With the pulse width reduced to zero, NO power is delivered due to these fault conditions until the next search interval. When these fault conditions occur, the STAT pin becomes high impedance to indicate that no power is being delivered to the RX coil. The only exception is when the input current exceeds the input current limit ( $I_{LIM}$ ). This particular fault condition does not cause the STAT pin to be high impedance.

This description is captured graphically in the flow chart of Figure 6 and Figure 13.

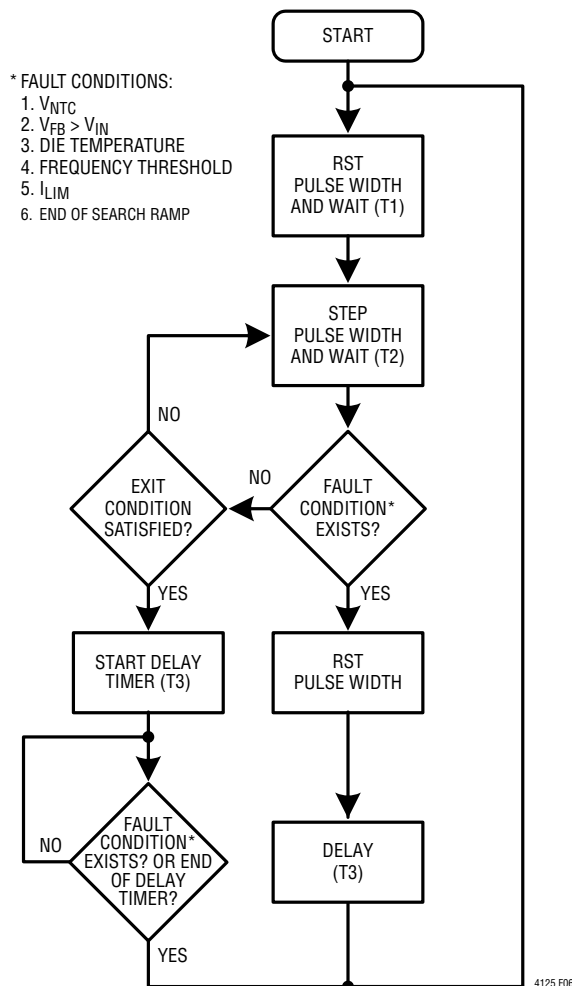

**Figure 6. Load Auto Detect Flow Chart**

## OPERATION

### Exit Conditions

The Optimum Power Search employs many exit conditions to ensure that the optimum transmit power is found during a search across many different operating situations. The primary exit conditions are not user programmable. Under most operating conditions, these primary exit conditions will produce the optimum transmit power.

However, two user programmable exit conditions are provided to enable additional functionality and improved performance in some scenarios: input current threshold and differential tank voltage threshold. Input current threshold is programmable using  $R_{IN}$ ,  $R_{IMON}$  and  $R_{IS}$ :

$$I_{TH} = \frac{R_{IN}}{R_{IMON}} \cdot \frac{V_{ITH}}{R_{IS}} = \frac{R_{IN}}{R_{IMON}} \cdot \frac{0.80V}{R_{IS}}$$

Referring to the Block Diagram,  $V_{IMON}$  is a gained up version of the differential voltage across  $R_{IS}$ . When  $V_{IMON}$  is greater than 0.80V ( $V_{ITH}$ , typ), the input current threshold is reached. When this occurs during an Optimum Power Search interval, the search stops and the pulse width is held until the next search interval.

The second user programmable exit condition sets a differential FB pin voltage threshold using the DTH pin. During the Optimum Power Search, this threshold is compared to the FB pin voltage increase resulting from one pulse width step to the next. If the threshold is exceeded, the exit condition is met. As described previously, when an exit condition is met, the pulse width (i.e. transmit power level) is held until the next search interval.

The DTH threshold is a useful exit condition when coupling between the transmit and receive coils is poor. Shorting the DTH pin to the IN pin will ensure that this exit condition is ignored. This default setting is sufficient in most applications. Please refer to the Applications Information section for details on how to program this pin.

### Fault Conditions

A fault condition will cause the Optimum Power Search to stop transmitting power immediately by keeping the pulse width at zero until the next search interval. There are six fault conditions: frequency (foreign object), NTC (external temperature), over voltage, end of search ramp, input current limit and internal (die) over temperature.

The frequency threshold is programmed by the FTH pin. If the AutoResonant Drive frequency exceeds the frequency threshold during the power search, then the search stops and the pulse width is reduced to zero. This condition may indicate the presence of a conductive foreign object. No power is delivered until the next search interval.

An external over temperature condition is detected via the NTC pin. If  $V_{NTC}$  falls below the NTC Hot Threshold (typically 35% of  $V_{IN}$ ) during the power search, then the search stops and the pulse width is reduced to zero. No power is delivered until the next search interval. The NTC thermistor can be used to monitor the temperature of the transmit coil to ensure safe operation of the coil. Furthermore, the presence of a conductive foreign object that generates heat when placed in the magnetic field of the coil can also be sensed with this technique.

Excessive tank voltage is detected via the FB pin voltage. If  $V_{FB}$  exceeds  $V_{IN}$  during the power search, then the search stops and the pulse width is reduced to zero. No power is delivered until the next search interval.

Another fault condition exists when the power search ramp has reached its maximum pulse width (50% duty cycle) and no optimum transmit power has been found. This typically indicates that no receiver is present or that a conductive foreign object is present between the transmit and receive coils preventing any significant power from being delivered to the receiver. Transmit power is reduced to zero until the next search interval.

## OPERATION

Input current limit is detected via the IMON pin. If the voltage on the IMON pin exceeds 1.20V ( $V_{ILIM, typ}$ ) after a valid exit condition is found, transmit power is reduced to zero until the next search interval. Input current limit is programmable using  $R_{IN}$ ,  $R_{IMON}$  and  $R_{IS}$ :

$$I_{LIM} = \frac{R_{IN}}{R_{IMON}} \cdot \frac{V_{ILIM}}{R_{IS}} = \frac{R_{IN}}{R_{IMON}} \cdot \frac{1.20V}{R_{IS}}$$

Referring to the Block Diagram,  $V_{IMON}$  is a gained up version of the differential voltage across  $R_{IS}$ . When  $V_{IMON}$  is greater than 1.20V ( $V_{ILIM, typ}$ ), the input current limit is reached. Notice that for the same values of  $R_{IN}$ ,  $R_{IMON}$  and  $R_{IS}$ , this input current limit is 150% (typ) of the input current threshold—one of the programmable valid exit conditions.

The final fault condition used in the algorithm is the die temperature of the LTC4125. If the internal die temperature of the LTC4125 ever exceeds 150°C (typ), then transmit power is immediately reduced to zero until the next search interval. Unlike other fault conditions, the die temperature fault is not limited to the duration of the Optimum Power Search period.

### $I_{TH}$ vs $I_{LIM}$

As noted in the previous two sections, there are two input current parameters whose values are determined by  $R_{IN}$ ,  $R_{IMON}$  and  $R_{IS}$ :  $I_{TH}$  (input current threshold) and  $I_{LIM}$  (input current limit). When the input current exceeds  $I_{TH}$  during the optimum power search, the search will stop and the LTC4125 maintains operation at or slightly above this input current level. However, if the input current exceeds  $I_{LIM}$  at any point during operation, power transmission will cease immediately until the next search interval. The input current limit is 150% (typ) of the input current threshold.

### $V_{PTH1}/V_{PTH2}$ and Pulse Width

The pulse width of each half of the full bridge driver can be monitored using the PTH1 and PTH2 pins. When AutoResonant drive is enabled, the pulse width is:

$$PW_{SWx}(s) = \left( \frac{0.24}{f_n} \cdot V_{PTHx} \right) + 150ns$$

where  $f_n$  is the full bridge resonant frequency, and 0.24 is the typical normalized PTH voltage to Pulse Width Gain. During the Optimum Power Search period, as the pulse width increases, the voltage on the PTH pins increases as well. When  $V_{PTH1}$  or  $V_{PTH2}$  exceeds 2.4V, the maximum pulse width is guaranteed to have been reached, and the end of search ramp fault condition stops power delivery until the next search interval. Again, this typically indicates that no receiver is present or that a conductive foreign object is present.

### PTHM

The pulse width of the first step in the Optimum Power Search can be programmed using the PTHM pin. This feature helps the Optimum Power Search find the appropriate pulse width when the minimum transmit power levels of the full bridge are known. This requires characterization of the application to know that the optimum operating point is always above a certain pulse width for all conditions. When PTHM is connected to ground, the first step defaults to 150ns.

## APPLICATIONS INFORMATION

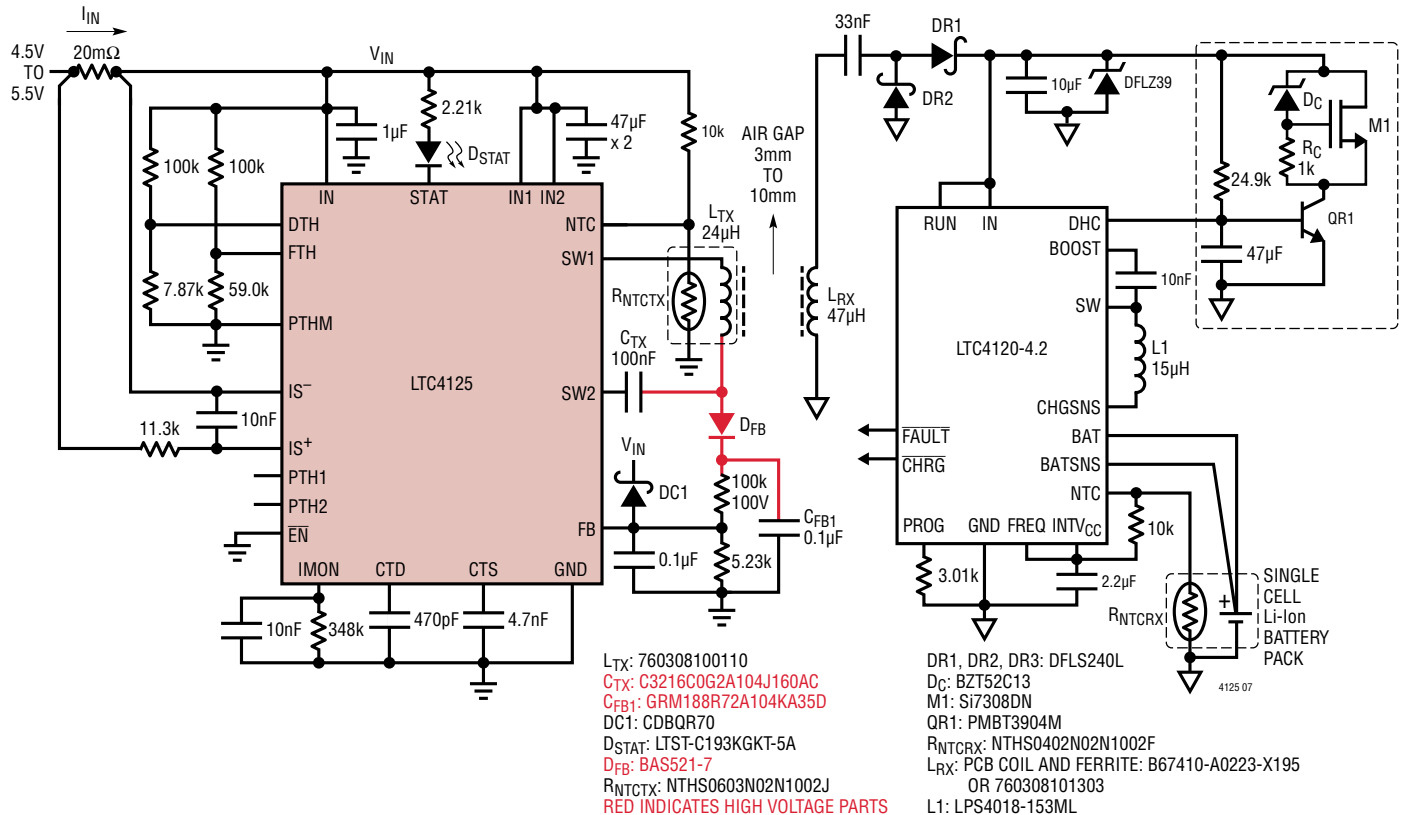

**Figure 7. LTC4125 Driving a 24µH Transmit Coil at 103kHz, with 1.3A Input Current Threshold, 119kHz Frequency Limit and 41.5°C Transmit Coil Surface Temperature Limit in a Wireless Power System with LTC4120-4.2 as a 400mA Single Cell Li-Ion Battery Charger at the Receiver**

In a typical design with LTC4125 (see Block Diagram for component labels), the following steps are usually followed: select a transmit coil ( $L_{TX}$ ), select a resonant capacitor ( $C_{TX}$ ), determine the feedback voltage divider ( $R_{FB1}$ ,  $R_{FB2}$ ), determine the input current monitor resistors ( $R_{IS}$ ,  $R_{IN}$ ,  $R_{IMON}$ ), determine the frequency threshold resistors ( $R_{FTH1}$ ,  $R_{FTH2}$ ), determine the Optimum Power Search Settling Time ( $C_{TS}$ ), determine the Optimum Power Search Delay Time ( $C_{TD}$ ), determine the pulse width of the first step in the Optimum Power Search ( $R_{PTH1}$ ,  $R_{PTH2}$ ), and finally, determine the differential FB pin voltage threshold ( $R_{DTH1}$ ,  $R_{DTH2}$ ).

The following discussion elaborates on factors that need to be considered for each of these steps. For further clarity, an example for each step is discussed in the context of the application circuit shown in Figure 7.

### TRANSMIT COIL SELECTION

There are several important parameters to consider when making the transmit coil/inductor selection: the inductor physical dimension, the inductance value, the inductor quality factor ( $Q_L$ ), and the inductor saturation current. All of these affect overall efficiency and power delivery capability.

The physical dimension of the coil is important as it affects the overall coupling between the transmit and receive coils. The ideal size and shape of the transmit coil varies depending on the application requirements. To name a few: the end product size, shape and power requirement, the freedom of placement desired in the final solution and cost. As a guideline, many of the readily available wireless power transmit coils are circular spiral coils with 50mm diameter (Table 1). These coils are recommended as a starting point when evaluating a design with LTC4125.



## APPLICATIONS INFORMATION

**Table 1. Recommended Transmit Coils**

| MANUFACTURER    | PART NUMBER         | INDUCTANCE (μH) | SIZE (mm) | QUALITY FACTOR AT 100kHz |
|-----------------|---------------------|-----------------|-----------|--------------------------|
| Würth           | 760308110           | 24              | 53 x 53   | 140                      |
| Würth           | 760308100110        | 24              | Dia. 50   | 140                      |
| Würth           | 760308100111        | 6.3             | Dia. 50   | 100                      |
| Inter Technical | L41200T06           | 5               | 52 x 52   | 80                       |
| TDK             | WT505090-20K2-A10-G | 24              | Dia. 50   | 50                       |
| TDK             | WT505090-10K2-A11-G | 6.3             | Dia. 50   | 100                      |

Another important parameter to consider is the inductance value of the coil itself. This value needs to be considered in relation to the receive coil inductance value and the overall wireless power system coupling between the transmit and the receive coil. The ratio of the two inductance values together with the coupling factor determines the voltage and current possible on the receive coil, and therefore the power delivery capability of the system.

The quality factor of an inductor at a particular frequency is defined as follows:

$$Q_L = \frac{\omega L}{R_L} = \frac{2\pi f L}{R_L}$$

where  $\omega$  is the target frequency in radians,  $f$  is the target frequency in Hz, and  $R_L$  is the inductor effective series resistance. The higher the  $Q$ , the more efficient that particular inductor is in carrying current at that frequency. A typical 24μH transmit coil that is used to deliver power up to 5W across a 1mm to 15mm distance has a quality factor of  $\approx 50$  to 150 at 100kHz operating frequency.

Many commercially available transmit coils use ferrite material to help boost the inductance value as well as shape the magnetic field created by the transmit coil to increase coupling and power delivery. However, ferrite material limits the saturation current level. The saturation current level needs to be higher than the maximum current amplitude generated in the LC resonant structure to ensure predictable inductance values and prevent potential thermal runaways. The monolithic switches inside the LTC4125 allow switches RMS current of up to 3.5A

( $I_{RMS-MAX}$ ) before thermal rise (from 25°C ambient) in the die causes the internal thermal shutdown to stop power delivery in the coil.

In the specific application shown in Figure 7, a 24μH coil (760308100110) from Würth is used. It has a 50mm diameter, a  $Q$  value of 140 at 100kHz as well as a saturation current greater than 10A.

### TRANSMITTER RESONANT CAPACITOR SELECTION

The factors to consider when selecting the transmitter capacitor are similar to the factors discussed previously when making the inductor choice: the capacitance value, the capacitor quality factor ( $Q_C$ ), and the voltage rating of the capacitor. The physical dimension of the capacitor is usually not a big factor since overall application size is driven mainly by the size of the transmit coil.

First and foremost the parameter to consider is the capacitance value itself. The LTC4125 is designed to work with resonant frequencies between 50kHz and 250kHz. The AutoResonant feature of the LTC4125 ensures that the series LC network is driven at the resonant frequency of the LC network:

$$f_0 = \frac{1}{2\pi\sqrt{LC}}$$

Another important factor is the parasitic dissipative component of the capacitance. As with the inductor, one way to measure this component is by looking at the quality factor of the capacitor. The capacitor quality factor is described as:

$$Q_C = \frac{1}{\omega C R_C} = \frac{1}{2\pi f C R_C}$$

where  $\omega$  is the target frequency in radians,  $f$  is the target frequency in Hz, and  $R_C$  is the capacitor effective series resistance. The higher the  $Q$ , the more ideal that particular capacitor is at that frequency.

For a given value of inductance, frequency and current amplitude, the voltage that is developed across the inductor and the capacitor is well defined. The capacitor voltage

## APPLICATIONS INFORMATION

rating must be able to withstand this voltage. The maximum voltage the capacitor must withstand is given by:

$$V_{C_{MAX}} = \frac{I_{L_{MAX}}}{\omega C} = \frac{\sqrt{2} \cdot I_{RMS\_MAX}}{\omega C}$$

where  $I_{L_{MAX}}$  is the maximum inductor current during operation in the series LC circuit.

In the specific application shown in Figure 7, a 100nF 100V COG capacitor (C3216COG2A104J160AC) is used. The Q value of the capacitor at 100kHz is not explicitly listed in the data sheet but based on empirical measurement it is much higher than the quality factor of the inductor selected. With an expected maximum RMS current of 3A (see Figure 9 in the Feedback section immediately following this section), and using the formula for  $V_{C_{MAX}}$  above, the maximum voltage developed across the capacitor is 65V.

At 100nF, the resonant frequency that results with the 24μH inductor is 103kHz. Notice that the LC tank on the receiver is tuned to 127kHz. This intentional difference in tuning frequency is to ensure that the DHC feature in the LTC4120 receiver IC functions properly given all the tolerances of the passive components—please see LTC4120 data sheet for details. For all other applications without a dynamic tuning feature, the transmit LC frequency should be tuned about 20% lower than the receive LC resonant frequency.

### FEEDBACK

The next step involved in a typical design is determining the values of the feedback resistors. LTC4125 monitors the voltage developed on the transmit coil via the feedback (FB) pin. The Optimum Power Search uses this FB pin voltage to determine an appropriate transmit power level. In order to detect the peak of the transmit coil voltage, a half wave rectifier consisting of a diode and a capacitor is used as shown in Figure 8. For the ensuing discussion, please refer to Figure 9 and Figure 13 as well.

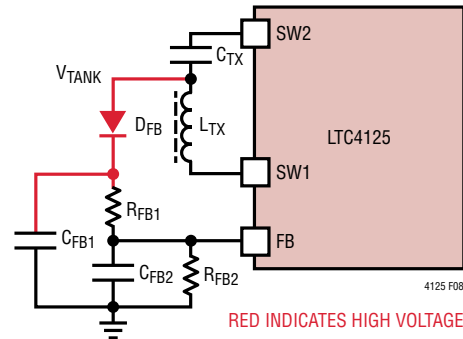

Figure 8. FB Pin Rectifier and Divider

The diode  $D_{FB}$  reverse voltage rating needs to withstand the highest peak-to-peak voltage generated at  $V_{TANK}$  across its operating range. From the resonant capacitor section, the peak-to-peak voltage generated in the tank is twice the maximum voltage developed across the capacitor. Therefore in the particular example shown in Figure 7, with an expected maximum RMS current of the LC tank at 3A, the maximum peak to peak voltage developed in the tank is 130V.

Aside from its reverse voltage rating, the other parameters of the diode are not critical—in most applications, the smallest packaged diode with the appropriate voltage rating is selected.

The capacitor  $C_{FB1}$  voltage rating needs to withstand the maximum peak voltage generated by the tank, which is 65V for the example shown in Figure 7.

The value of  $C_{FB1}$  is also important. The value needs to be selected such that the time constant  $C_{FB1}(R_{FB1}+R_{FB2})$  is smaller than twice the time interval  $T_2$ —the settling time after each step. This ensures that the voltage developed at  $C_{FB1}$  has enough time to settle at each step during the sweep. Therefore, the value of  $C_{FB1}$  needs to satisfy the following criteria:

$$C_{FB1} < \frac{T_2}{2(R_{FB1} + R_{FB2})} = \frac{(1.92 \cdot 10^6) C_{TS}}{R_{FB1} + R_{FB2}} = 0.1\mu F \text{ (typ)}$$



## APPLICATIONS INFORMATION

The recommended values for  $R_{FB1}$  and  $R_{FB2}$  are such that  $R_{FB1} + R_{FB2} \approx 100k$ . A typical recommended starting value for  $C_{FB1}$  is  $0.1\mu F$ . Refer to the Timer Capacitor section in the later part of this Applications Information on details for setting the value of  $T2$ .

The capacitor  $C_{FB2}$  is optional in most applications. It can be used to clean up the signal at the FB pin further. This capacitor voltage rating only needs to be 6V or less, and its value needs to be selected such that the time constant  $C_{FB2} (R_{FB2} // R_{FB1})$  is again less than twice the time interval  $T2$ —the wait time after each step. Therefore, the value of  $C_{FB2}$  needs to satisfy the following criterion:

$$C_{FB2} < \frac{T2}{2(R_{FB1} // R_{FB2})} = \frac{(1.92 \cdot 10^6) C_{TS}}{R_{FB1} // R_{FB2}}$$

A  $0.1\mu F$   $C_{FB2}$  capacitor is recommended and sufficient for most applications.

The ratio of the resistor divider  $R_{FB1}$  and  $R_{FB2}$  is selected based on the maximum tank voltage ( $V_{TANK}$ ). Follow these steps when determining the maximum tank voltage:

1. Set the distance and orientation of the receiver coil with respect to the transmit coil for the lowest coupling (this condition usually requires the highest tank current, and therefore, the highest tank voltage).
2. Short the two LTC4125 PTH pins together.
3. Sweep  $V_{PTH}$  voltage.
4. Monitor the following: (see Figure 9)
  - a. Transmit tank voltage ( $V_{TANK}$  in Figure 8)
  - b. Transmit circuit input RMS current
  - c. Rectified voltage at the receiver
  - d. Charge current at the receiver

Figure 9 shows this sweep for the circuit shown in Figure 7. Note that the LTC4120 is set to charge a single cell Li-Ion battery in the Constant Current mode at 400mA at the maximum target separation of 10mm.

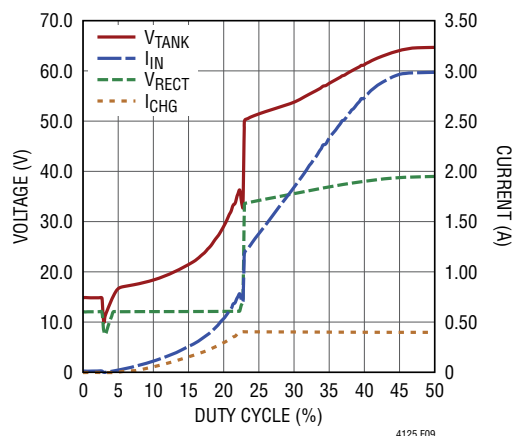

**Figure 9.  $V_{TANK}$ ,  $I_{IN}$ ,  $V_{RECT}$  and  $I_{CHG}$  vs Duty Cycle with LTC4120 at the Receiver in CC Mode at 10mm Spacing**

In this particular example, the tank voltage generated at the optimum point is 50V ( $V_{TANK-MAX}$ ), and the maximum input RMS current is 1.3A. To prevent an FB voltage overrange fault, the divider needs to ensure that when  $V_{TANK} = 55V$ ,  $V_{FB}$  is less than  $V_{IN}$ —note 55V is picked to give ~10% margin above the observed 50V max tank voltage. Therefore, the resistor divider ratio should be set according to the following formula:

$$V_{TANK-MAX} < \left( \frac{R_{FB1}}{R_{FB2}} + 1 \right) \cdot V_{IN} + V_D$$

$$\frac{R_{FB1}}{R_{FB2}} > \frac{V_{TANK-MAX} - V_D}{V_{IN}} - 1 \approx \frac{55 - 1}{5} - 1 = 10$$

where  $V_D$  is the diode drop of the rectification diode used to rectify the LC tank voltage. Note that for a robust design, functionality at all operating conditions needs to be reverified once the feedback resistor dividers and capacitors are chosen.

## APPLICATIONS INFORMATION

## INPUT CURRENT LIMIT SETTING AND MONITORING

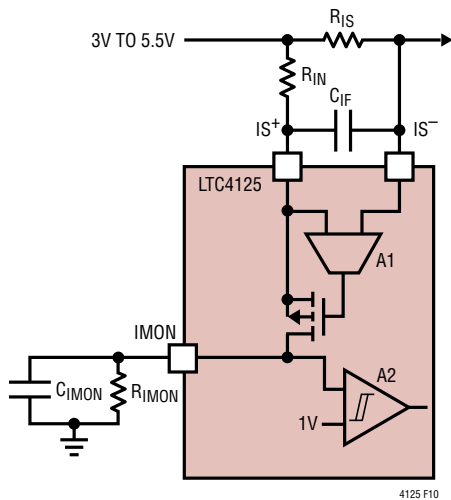

Figure 10. Input Current Limit and Monitoring

Figure 10 shows the architecture employed by the LTC4125 for the input current monitoring. The input current threshold, used as one of the exit conditions in the proprietary Optimum Power Search algorithm, is set using a combination of  $R_{IS}$ ,  $R_{IN}$  and  $R_{IMON}$  resistors according to the following formula:

$$I_{TH} (A) = \frac{R_{IN}}{R_{IMON}} \cdot \frac{V_{ITH}}{R_{IS}} = \frac{R_{IN}}{R_{IMON}} \cdot \frac{0.80V}{R_{IS}}$$

where 0.80V is the typical  $V_{ITH}$ .

The input current through the sense resistor  $R_{IS}$  is available for monitoring through the IMON pin. The voltage at the IMON pin varies with the current through the sense resistor ( $R_{IS}$ ) as follows:

$$V_{IMON} = \frac{R_{IMON} \cdot R_{IS}}{R_{IN}} \cdot I_{RIS}$$

One of the fault conditions, the input current limit, is also detected via the IMON pin. If the input current limit is reached after a valid exit condition is found, transmit power

is reduced to zero until the next search interval. Input current limit is also programmable using  $R_{IN}$ ,  $R_{IMON}$  and  $R_{IS}$ :

$$I_{LIM} = \frac{R_{IN}}{R_{IMON}} \cdot \frac{V_{ILIM}}{R_{IS}} = \frac{R_{IN}}{R_{IMON}} \cdot \frac{1.20V}{R_{IS}}$$

where 1.20V is the typical  $V_{ILIM}$ .

As mentioned in the Operation section, for the same values of  $R_{IN}$ ,  $R_{IMON}$  and  $R_{IS}$ , this input current limit is 150% of the input current threshold.

Notice that the user has the ability to set the input current threshold and limit by choosing values for three different components. For most applications, the voltage drop across  $R_{IS}$  at the current limit threshold is recommended to be less than 50mV, and the ratio of  $R_{IMON}$  to  $R_{IN}$  to be in the range of 10-40, with  $R_{IN}$  in the order of 10k $\Omega$ .

In the Figure 7 example, the desired current threshold and limit are 1.3A and 1.95A respectively. The  $R_{IS}$  is set to be 20m $\Omega$  to limit the drop across it to 40mV at the input current limit. With  $R_{IN}$  set to 11.3k $\Omega$ , the  $R_{IMON}$  value is 348k $\Omega$ , yielding the final current threshold and limit of 1.3A and 1.95A respectively.

If the input current is time varying or noisy, as would be expected of a sinusoidal load of an LC tank, add filtering capacitors  $C_{IF}$  and  $C_{IMON}$  to obtain a time average voltage at the IMON pin that corresponds to the time average value of the current through the input current sense resistor. The value of  $C_{IF}$  and  $C_{IMON}$  should be selected such that the time constants  $R_{IN}C_{IF}$  and  $R_{IMON}C_{IMON}$  are less than  $T_2$ —the settling time interval between each step in the Optimum Power Search algorithm (Figure 6). This is to ensure that a current threshold exit condition can be detected within a single step in the search. In the example of Figure 7, both  $C_{IF}$  and  $C_{IMON}$  are set to 10nF.

### FREQUENCY THRESHOLD (FTH PIN)

As discussed in the Operation section, the AutoResonant Drive used in the LTC4125 drives the external LC tank at its resonant frequency. The frequency threshold input (FTH) serves as the primary protection feature against inadvertently transmitting power into a foreign object.

## APPLICATIONS INFORMATION

An internal frequency to voltage converter creates a voltage representation of this AutoResonant Drive frequency (Block Diagram). When a foreign conductive object is brought close to the transmit coil, the apparent inductance of the transmit coil is dramatically reduced and the driving frequency of the LTC4125 adjusts to a higher frequency.

Figure 11 shows the contrast between the tank voltage frequency with and without the presence of a small conductive foreign object. The circuit in Figure 7 is used to generate this figure with the two PTH pins shorted together and driven at 0.5V, and a 15mm × 15mm copper square plate placed directly on top of the coil as a conductive foreign object.

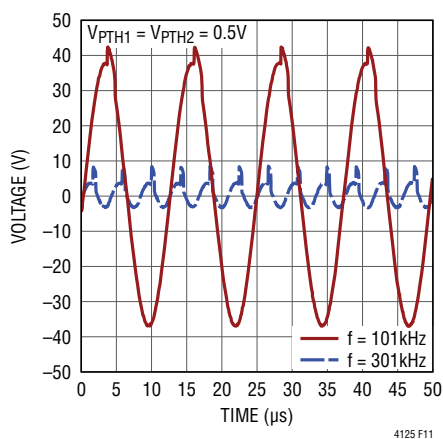

**Figure 11. Comparison of the LC Tank Voltage Frequency without and with the Presence of a Conductive Foreign Object**

The frequency limit is programmed via the FTH pin with the following formula:

$$f_{LIM} = \frac{V_{FTH}}{V_{IN}} \cdot 320\text{kHz} = \frac{R_{FTH2}}{R_{FTH1} + R_{FTH2}} \cdot 320\text{kHz}$$

Note that the internal frequency to voltage converter is discretized to 7 bits with a full input range between 0kHz and 320kHz. Therefore, the accuracy of the frequency threshold input is limited to ±2.5kHz. The total resistance of  $R_{FTH1}$  plus  $R_{FTH2}$  is recommended to be in the order of 100kΩ.

Figure 12 shows the difference in LTC4125 behavior when a conductive foreign object is placed on the transmit coil, with or without a frequency limit programmed at the FTH pin. Again, the same circuit in Figure 7 is used.

Note that without the FTH pin programmed (tied to  $V_{IN}$ ), the LTC4125 does not detect a valid receiver circuit, and therefore limits the power delivered to a foreign object to only pulses of power that are generated during a search interval. Without a valid receiver, the search fails to find a valid exit condition until it reaches the end of the power search ramp fault condition, which causes the transmitter to stop delivering power before the next search interval.

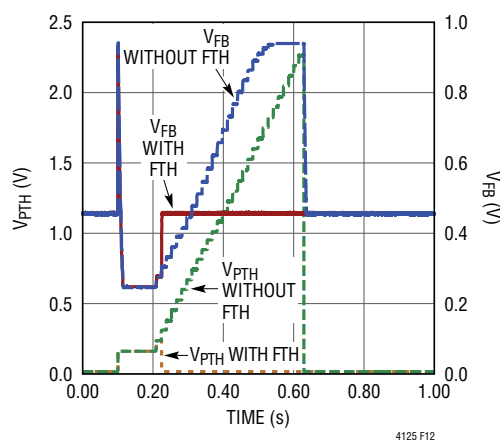

**Figure 12. Comparison of the PTH and FB Pins Waveforms with and without the FTH Pin Programmed to Detect the Presence of a Conductive Foreign Object**

Therefore, without using FTH, these pulses of power will continue to deliver a limited amount of power to the foreign object. To eliminate even this small amount of transmitted power, the FTH pin can be programmed to about 10% to 15% higher than the expected resonant frequency (as determined by the tank inductance and capacitance). If this frequency limit is exceeded at any point during the search interval (typically at the first step), the LTC4125 will cease to deliver any power to the object and the STAT pin will be set to high impedance to indicate that the transmit coil is not delivering any power.

In the example shown in Figure 7, the tank frequency is 103kHz, and the frequency threshold is set to be 119kHz, with  $R_{FTH2} = 59\text{k}\Omega$  and  $R_{FTH1} = 100\text{k}\Omega$ .

## APPLICATIONS INFORMATION

### TIMER CAPACITORS— $C_{TS}$ AND $C_{TD}$

The capacitor connected to the CTS pin ( $C_{TS}$ ) sets the CTS frequency ( $f_{CTS}$ ) which determines the step settling time in the Optimum Power Search. This CTS frequency can be programmed as follows:

$$f_{CTS} = \frac{10\mu A}{C_{TS} \cdot 1.2V}$$

where  $10\mu A$  is the typical  $I_{CTS,PU}$  and  $I_{CTS,PD}$ .

Similarly the capacitor connected to the CTD pin ( $C_{TD}$ ) sets the CTD frequency that can be programmed as follows:

$$f_{CTD} = \frac{10\mu A}{C_{TD} \cdot 1.2V}$$

where  $10\mu A$  is the typical  $I_{CTS,PU}$  and  $I_{CTD,PD}$ .

Referring to Figure 6 and Figure 13, the two timing intervals that use CTS frequency are T1—the wait time after the initial reset at the beginning of the search, and T2—the settling time after each pulse width step. The timing interval that uses CTD frequency is T3—the delay time from the end of one search to the beginning of the next search. The three values are related to the timer frequencies as follows:

$$T1 = \frac{256}{f_{CTS}} \quad T2 = \frac{32}{f_{CTS}} = \frac{T1}{8} \quad T3 = \frac{65 \cdot 10^3}{f_{CTD}}$$

For the recommended  $C_{TS} = 4.7nF$  and  $C_{TD} = 470pF$ , these timing intervals are  $T1 = 144ms$ ,  $T2 = 18ms$ , and  $T3 = 3.7s$ . The values of T1 and T2 need to be large enough such that the system has time to settle back to its zero value after reset (T1), and to settle to its new value after each step (T2). For the recommended resonant frequency range of 50kHz to 250kHz, a starting value for the recommended  $C_{TS}$  capacitor value is 4.7nF.

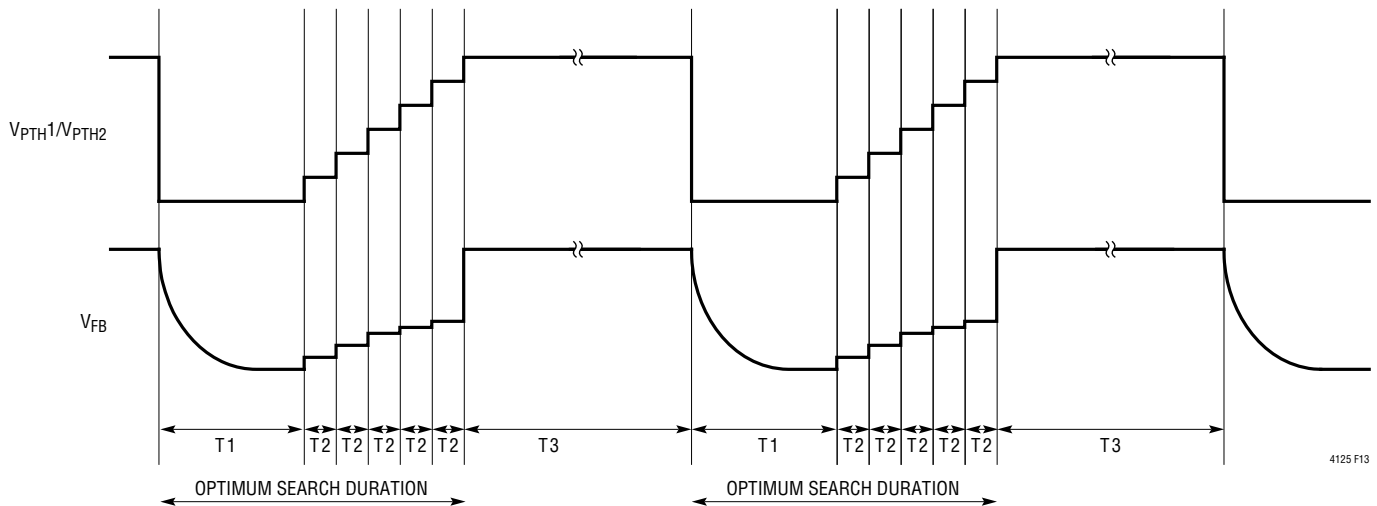

Figure 13. Timing Diagram of Typical Search Cycles

## APPLICATIONS INFORMATION

The value of T3 determines the delay interval time between each search. A starting value of 470pF for the C<sub>TD</sub> capacitor sets this delay time between each search to 3.7s.

Figure 14 shows the voltage stepping at FB, PTH1 and PTH2 for the circuit in Figure 7 with C<sub>TS</sub> = 4.7nF, showing a successful sweep in finding an optimum power point. Note that V<sub>PTHx</sub> corresponds to the full bridge pulse width while V<sub>FB</sub> corresponds to the transmit tank voltage.

### MINIMUM PULSE WIDTH (PTHM PIN)

In a typical search as shown in Figure 14, the first pulse width step is about 150ns. This corresponds to the minimum voltage on the PTHx pins (see the earlier V<sub>PTH1</sub>/V<sub>PTH2</sub> and Pulse Width section for more information).

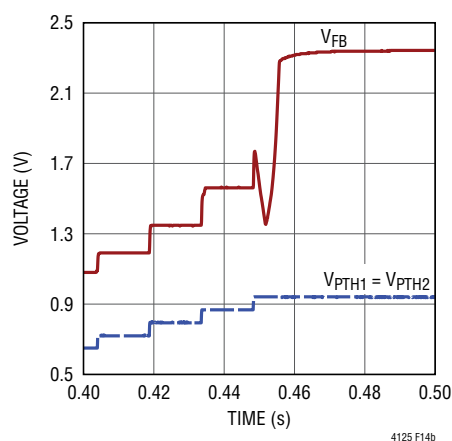
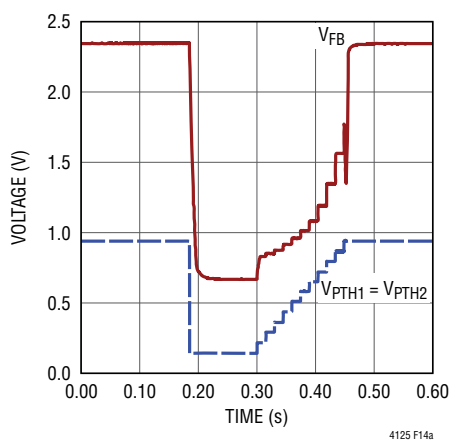

Figure 14. FB, PTH1 and PTH2 Pins Voltage Stepping During a Sweep with C<sub>TS</sub> = 4.7nF

In some applications users may find that across all operating conditions, the pulse width never falls below a particular value at the end of a search cycle. This indicates that the lowest transmit power levels of the full bridge are not required. If this is the case, the PTHM pin can be used to program the size of the first step of the pulse width sweep in the Optimum Power Search to reduce the search time. This minimum pulse width value can be set according to the following formula:

$$\text{MINPW} = \left( \frac{0.576}{f_n} \cdot \frac{V_{\text{PTHM}}}{V_{\text{IN}}} \right) + 150\text{ns}$$

where 0.576 is the product of 0.24V<sup>-1</sup> (the typical normalized PTH voltage to pulse width gain) and 2.4V (the typical maximum output voltage at the PTH pin).

Using a resistor divider between V<sub>IN</sub> and GND to set the voltage at the PTHM pin, the formula is simplified as follows:

$$\text{MINPW} = \left( \frac{0.576}{f_n} \cdot \frac{R_{\text{PTHM2}}}{R_{\text{PTHM1}} + R_{\text{PTHM2}}} \right) + 150\text{ns}$$

where f<sub>n</sub> is the resonant frequency of the LC tank.

Figure 15 contrasts the Optimum Power Search behavior when using PTHM versus when PTHM is grounded. The circuit in Figure 7 is used to generate Figure 15, with PTHM set to 1.6V in one case and grounded in the other. Again, remember that V<sub>PTHx</sub> corresponds to the full bridge pulse width while V<sub>FB</sub> corresponds to the transmit tank voltage.

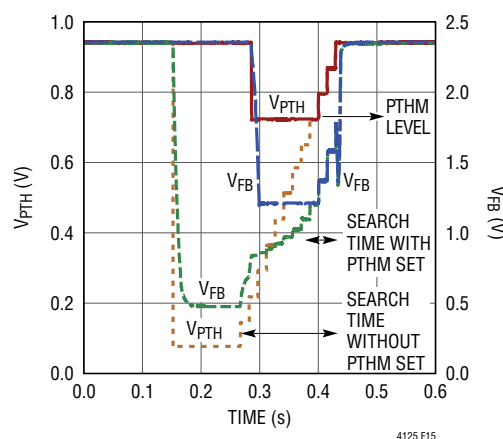

Figure 15. Comparison of the PTH Pins Voltage Steps During a Sweep with PTHM at GND and Programmed at a Particular Value

## APPLICATIONS INFORMATION

### DELTA THRESHOLD (DTH PIN)

One of the exit conditions in the Optimum Power Search algorithm is when the increase in the feedback voltage ( $V_{FB}$ ) at any particular step during the sweep is larger than  $V_{DTH}$ . In a typical sweep such as shown by the voltage steps in Figure 14, multiple exit conditions implemented by the LTC4125 to detect the optimum transmit power are satisfied. Therefore the DTH programmable exit condition is not required. However, some situations may benefit from using DTH.

In the example circuit of Figure 7, the  $V_{DTH}$  exit condition is useful in order to find the optimum power when the LTC4120 receiver circuit has the lowest output power at the highest target separation (lowest coupling). Figure 16 shows an example of voltage stepping at the feedback pin when the LTC4120 is charging a single cell Li-Ion battery in trickle charge constant current mode at 40mA ( $V_{BAT} = 2.7V$ ), at a 10mm distance. The dotted lines show the stepping at the FB and PTH pins when DTH is left open, and the second graph shows the stepping at the same pins when DTH is programmed appropriately.

In this particular example, the desired optimum power point corresponds to when  $I_{CHG}$  at the receiver is regulated at its desired target of 40mA. In this low load, low

coupling condition, this exit point also coincides with a voltage step at the feedback pin that is larger than all the earlier voltage steps.

Note that Optimum Power Search only deems this condition of  $\Delta V_{FB} > V_{DTH}$  valid when it follows a step where  $\Delta V_{FB}$  is less than  $V_{IN}/64$ . In the example shown in Figure 16,  $\Delta V_{FB}$  immediately preceding the optimum point is 24mV, and  $\Delta V_{FB}$  at the optimum point is 432mV.

In order to detect the optimum point in this example, the DTH pin needs to be programmed for a particular threshold (less than 432mV) to allow the  $\Delta V_{FB} > V_{DTH}$  exit condition. The DTH threshold is programmed with a resistor divider between  $V_{IN}$  and GND as follows:

$$V_{DTH} = \frac{R_{DTH2}}{R_{DTH1} + R_{DTH2}} \cdot V_{IN}$$

The FB pin voltage is sampled with an internal 7-bit A/D, and the DTH pin comparator is also quantized to 7 bits with both sharing a full input range of GND to  $V_{IN}$ . Therefore, the  $\Delta V_{FB} > V_{DTH}$  exit condition is subject to a 7-bit quantization or rounding error.

In this example, with  $V_{IN} = 5V$ , the LSB of the 7-bit A/D is 39mV. Therefore, 432mV of  $V_{FB}$  step gives 11.08 bits.

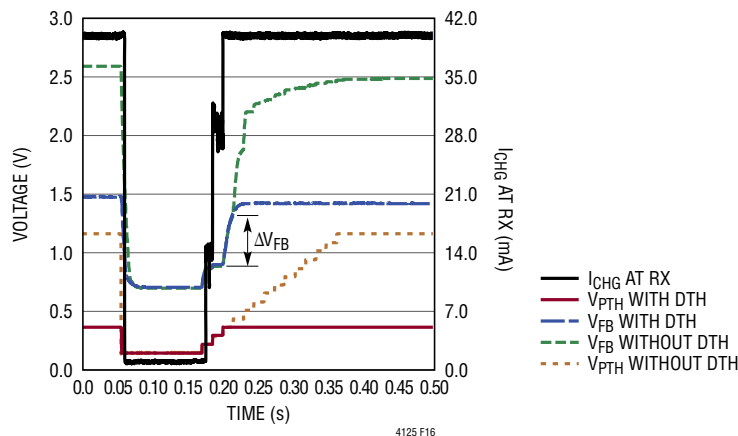

**Figure 16.  $V_{FB}$  Voltage Stepping During A Sweep with LTC4120 in Trickle Charge CC Mode as the Receiver Circuit at 10mm Spacing**



## APPLICATIONS INFORMATION

Set the  $V_{DTH}$  value to 9.4 bits = 367mV, such that at this desired step the  $\Delta V_{FB} > V_{DTH}$  condition is satisfied. With  $V_{IN} = 5V$ , and a recommended  $R_{DTH1} + R_{DTH2}$  value in the order of 100k $\Omega$ , the following values are obtained:  $R_{DTH2} = 7.87k\Omega$  and  $R_{DTH1} = 100k\Omega$ .

### OVER TEMPERATURE FAULT THRESHOLD

One of the fault conditions used in the Optimum Power Search is the overtemperature fault. To set this temperature fault threshold, connect an NTC thermistor  $R_{NTC2}$ , between the NTC pin and the GND pin, and a resistor  $R_{NTC1}$ , from the IN pin to the NTC pin (Figure 17). In a typical application, the NTC thermistor is thermally coupled to the surface of the transmitting coil, and the temperature threshold is set to ensure safe temperature on the coil surface.

In the simplest application,  $R_{NTC1}$  is a 1% resistor with a value equal to the value of the chosen NTC thermistor at 25°C ( $R_{NTC2}$  at 25°C). In this simple setup, the LTC4125 senses a fault condition when the resistance of the NTC thermistor drops to 0.538 times the value of  $R_{NTC2}$  at 25°C. For a Vishay “Curve 2” thermistor ( $B_{25}/B_{85} = 3486$ ), this corresponds to approximately 41.5°C. With a Vishay “Curve 2” thermistor, the LTC4125 has approximately 5°C of hysteresis to prevent oscillation about the trip point.

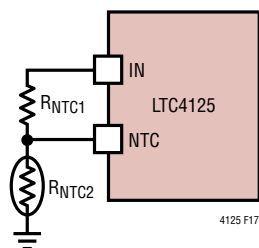

Figure 17. NTC Thermistor Connection

Consult manufacturer data sheets for other types of NTC thermistors. The temperature threshold can be adjusted by changing the value of  $R_{NTC1}$ . Instead of simply setting  $R_{NTC1}$  to be equal to  $R_{NTC2}$  at 25°C,  $R_{NTC1}$  is set according to the following formulas:

$$R_{NTC1} = 1.857 \cdot R_{NTC2} \text{ at temperature\_threshold}$$

As a quick rule of thumb, changing the value of  $R_{NTC1}$  to be smaller relative to  $R_{NTC2}$  at 25°C will move the temperature threshold higher and vice versa. For example, using a Vishay “Curve 2” thermistor whose nominal value at 25°C is 10k $\Omega$ , the user can set the temperature to be at 50°C by setting the value of  $R_{NTC1} = 7.5k\Omega$ .

Leaving the NTC pin open or connecting it to a capacitor disables all NTC overtemperature fault functionality.

### LTC4120 EFFICIENCY OPTIMIZER USING DHC

When using the LTC4125 in a wireless power system with the LTC4120, the DHC pin on the LTC4120 can be configured to further optimize the overall efficiency of the system (see Figure 7—circuit enclosed with dotted lines). Instead of driving a capacitor, the DHC pin turns on a 15V clamp circuit ( $D_C$ ,  $R_C$ ,  $M1$ ) on the rectified input voltage of the receiver circuit. Note that under some worst case transient conditions, the 15V clamp needs to dissipate up to 0.8W.

The 15V clamp voltage is selected to provide 1V margin to the LTC4120 14V DHC pin threshold. The RC network value connected to the DHC pin is selected to provide enough delay to allow the input voltage on the LTC4120 to rise to 39V (allowing for optimum power detection on the LTC4125) before the 15V clamp is activated. The following criteria should be followed:

$$\frac{RC}{(V_{ZH} - V_{BE})} > 1.5 \cdot T2$$

Where  $T2$  is the settling time of the optimum power search step discussed in the Timer Capacitors section. In Figure 7,  $V_{ZH} = 39V$ ,  $V_{BE} = 0.7V$  and  $T2$  is 18ms. Therefore, the value of RC needs to be greater than 1s. Note that the resistance value is chosen such that at the 15V clamp voltage, the NPN base current supplied through the resistor is greater than 0.5mA. Therefore, select 24.9k for R and 47 $\mu$ F for C.

The most important criteria for the NPN is that the common-emitter current gain at  $I_b = 0.5mA$  is greater than 50, and its maximum power dissipation capability is greater than 0.5W. A standard 3904 NPN works well.

## APPLICATIONS INFORMATION

### BOARD LAYOUT CONSIDERATIONS

When using an LTC4125 circuit, care must be taken when handling the board since high voltage is generated in the resonant LC tank. Figure 18 indicates in red the high voltage nodes that are present in a typical circuit. With careful layout the area of these high voltage nodes should be minimized and isolated for safe and simple operation.

For accurate sensing of the input current, the sense lines from  $R_{IS}$  must use proper Kelvin connections all the way back to the sense resistor terminals as shown in Figure 18. The lines connected to these resistors must be routed close together (the loop area between the sense traces should be kept to a minimum) and away from noise sources (such as the transmit coil) to minimize error. The gain resistor  $R_{IN}$  and filtering capacitor  $C_{IF}$  should be placed close to the LTC4125, so that the filtered high impedance lines do not need to travel far before reaching the  $IS^+$  and  $IS^-$  pins.

The decoupling capacitors  $C_{IN}$ ,  $C_{IN1}$  and  $C_{IN2}$  must be placed as close to the LTC4125 as possible. This allows as short a route as possible (minimized inductance) from these capacitors to the respective IN pins and the GND pins of the part. Figure 18 indicates in blue and green the hot current loops flowing through  $C_{IN1}$ , IN1, SW1 and GND; as well as through  $C_{IN2}$ , IN2, SW2 and GND. The physical layout of these hot current loops should be made as small as possible to minimize parasitic resistance as well

as inductance in the loop. Although the inductance of the trace between the LTC4125 and the transmit coil does not matter, the resistance does. Use a trace that is the shortest, and has maximum available copper thickness and width.

Last but not least, the amount of current flowing in the transmit coil can be significant. This current also flows through the switches in the LTC4125. For an application with a high quality factor transmit coil and resonant capacitor, it is not rare to have current upward of 2.5A RMS. At 2.5A, the power dissipation in the LTC4125 is approximately 1.25W (in a full bridge setup, the current always flows through two switches  $\sim 0.2\Omega$ ). With a  $\theta_{JA}$  of  $43^\circ\text{C/W}$ , the LTC4125 part will operate at roughly  $55^\circ\text{C}$  above ambient temperature.

In order to ensure that these quoted thermal resistance numbers are realized, the following good layout practices should be followed: use the maximum copper weight in the board layers as practically and economically possible, place the recommended number of vias connected to the exposed pad of the part (refer to LTC Application Notes for thermal enhanced leaded plastic packages available at [www.linear.com](http://www.linear.com)), and use the maximum size of GND plane connected to these vias. For proper operation of the LTC4125, ensure that other common good board layout practices are also followed. These include isolating noisy power and signal grounds, having a good low impedance

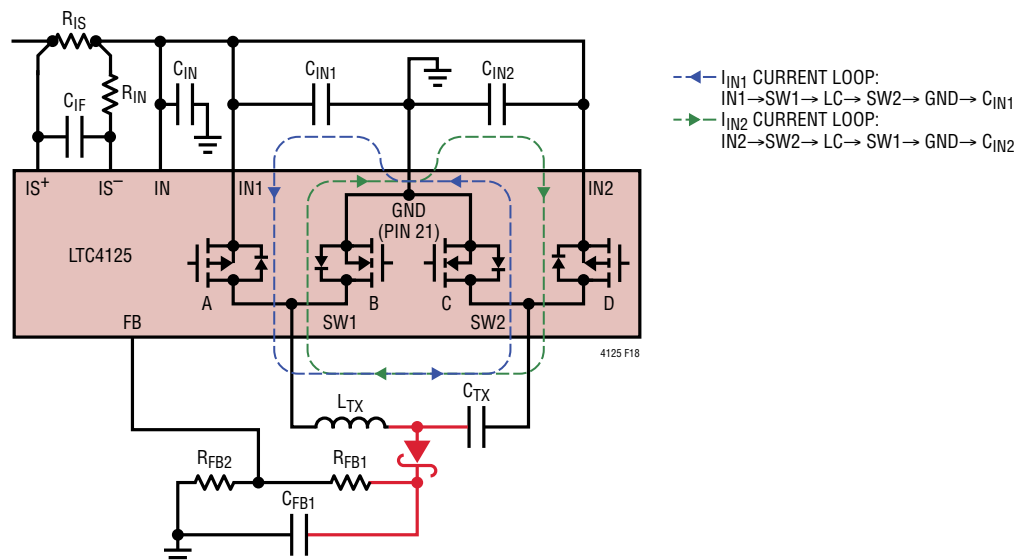

Figure 18. High Voltage Nodes (Red), Kelvin Lines and Hot Current Loops in the LTC4125 Circuit

4125f



## APPLICATIONS INFORMATION

ground plane, shielding whenever necessary, and routing sensitive signals as short as possible and away from noisy sections of the board.

Figure 19 shows an example of a 4-layer board recommended layout for the LTC4125 application circuit with the high voltage nodes and hot current loop highlighted.

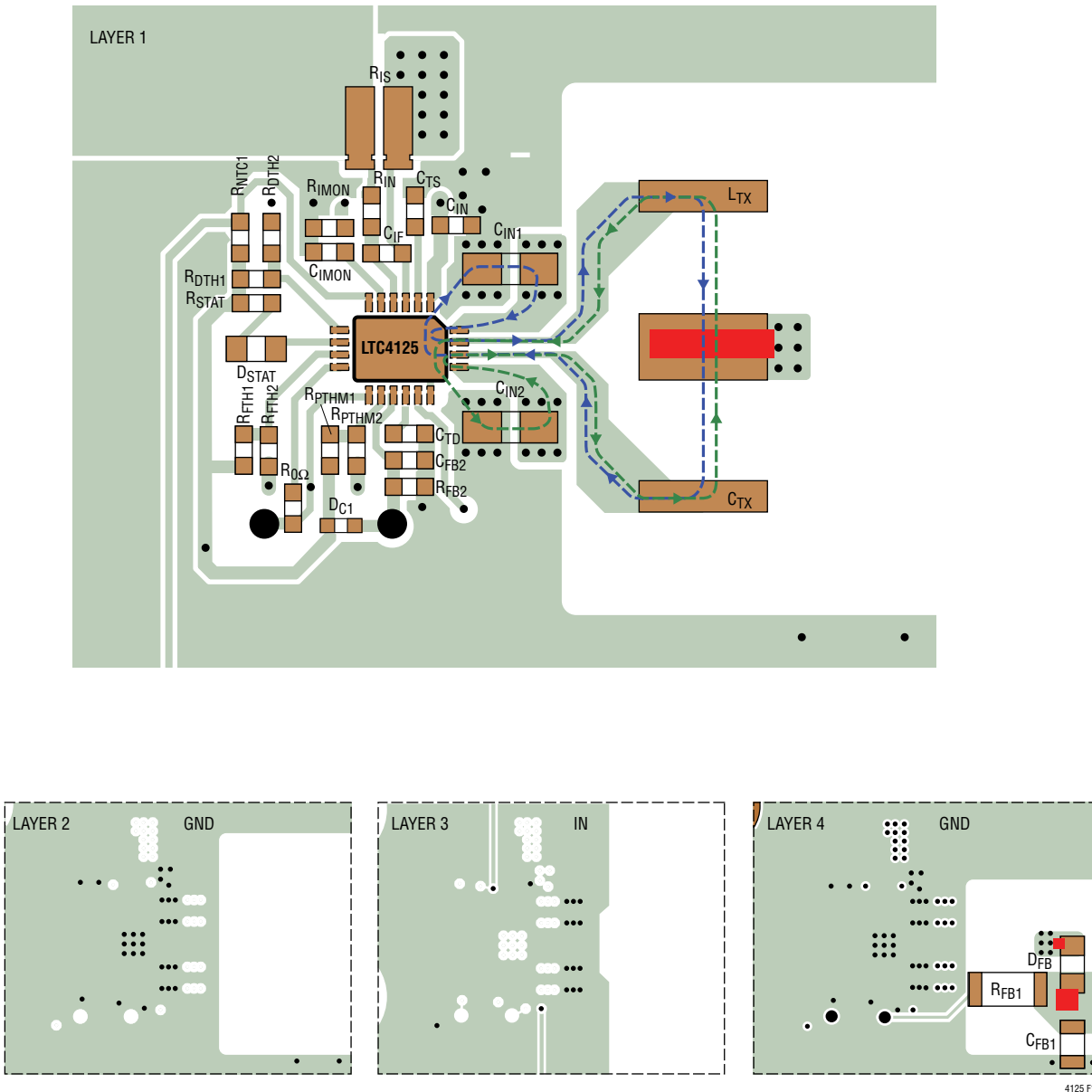
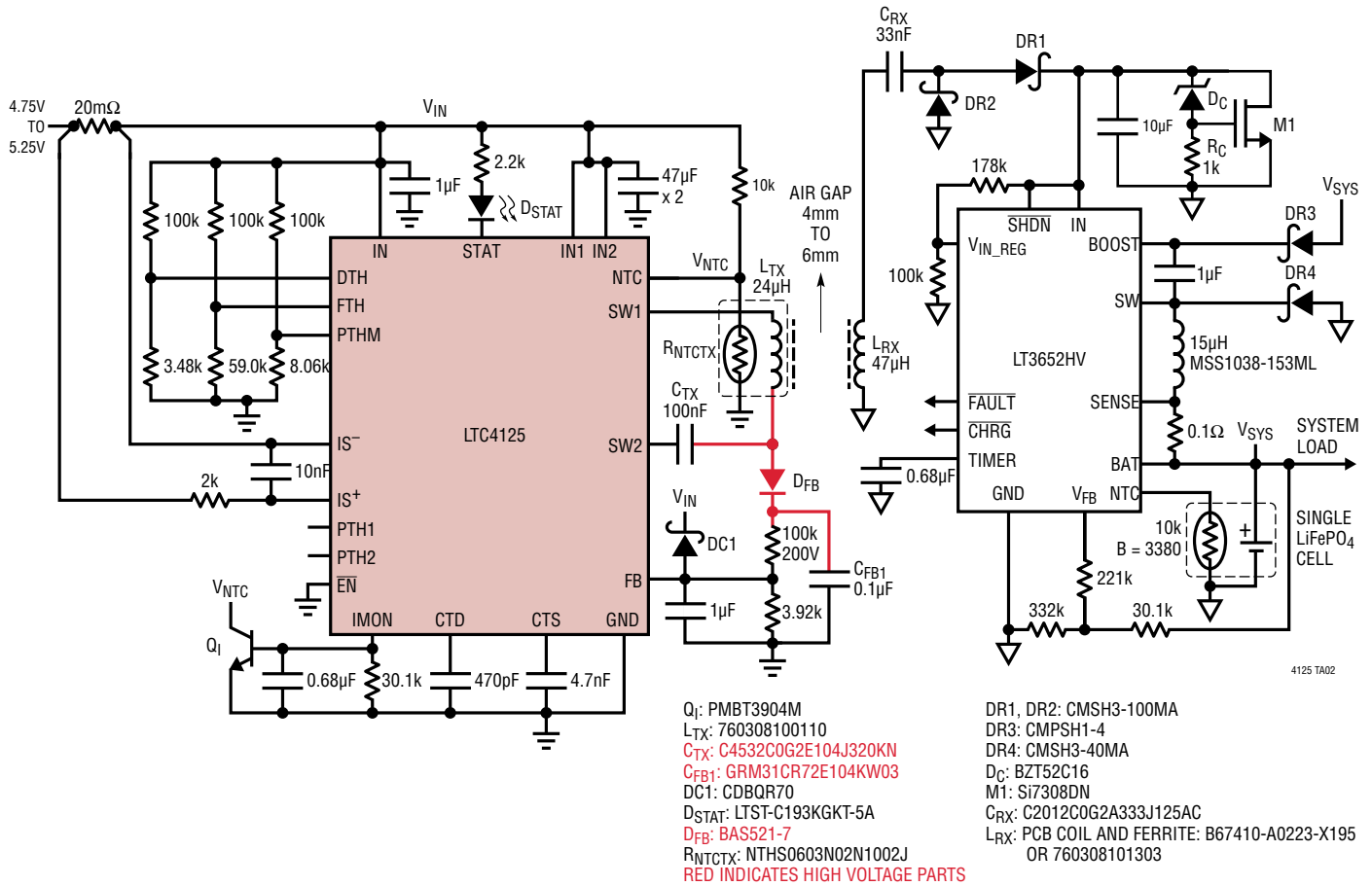

Figure 19. Example Layout of an LTC4125 Application Circuit on a 4-Layer Board with Red Indicating High Voltage Region See also Demo Board DC2330A available at [www.linear.com](http://www.linear.com)

## TYPICAL APPLICATIONS

**LTC4125 Driving a 24 $\mu$ H Transmit Coil at 103kHz, 119kHz Frequency Limit and 41.5°C Transmit Coil Surface Temperature Limit in a Wireless Power System with LT3652HV as a 1A Single Cell LiFePO<sub>4</sub> (3.6V Float) Battery Charger at the Receiver**



# PACKAGE DESCRIPTION

Please refer to <http://www.linear.com/product/LTC4125#packaging> for the most recent package drawings.

**UFD Package**  
**20-Lead Plastic QFN (4mm × 5mm)**  
 (Reference LTC DWG # 05-08-1711 Rev B)

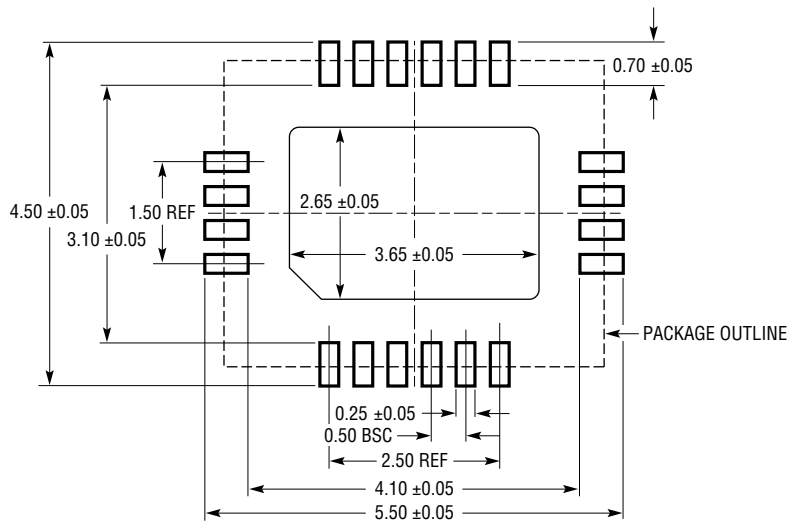

RECOMMENDED SOLDER PAD PITCH AND DIMENSIONS  
 APPLY SOLDER MASK TO AREAS THAT ARE NOT SOLDERED

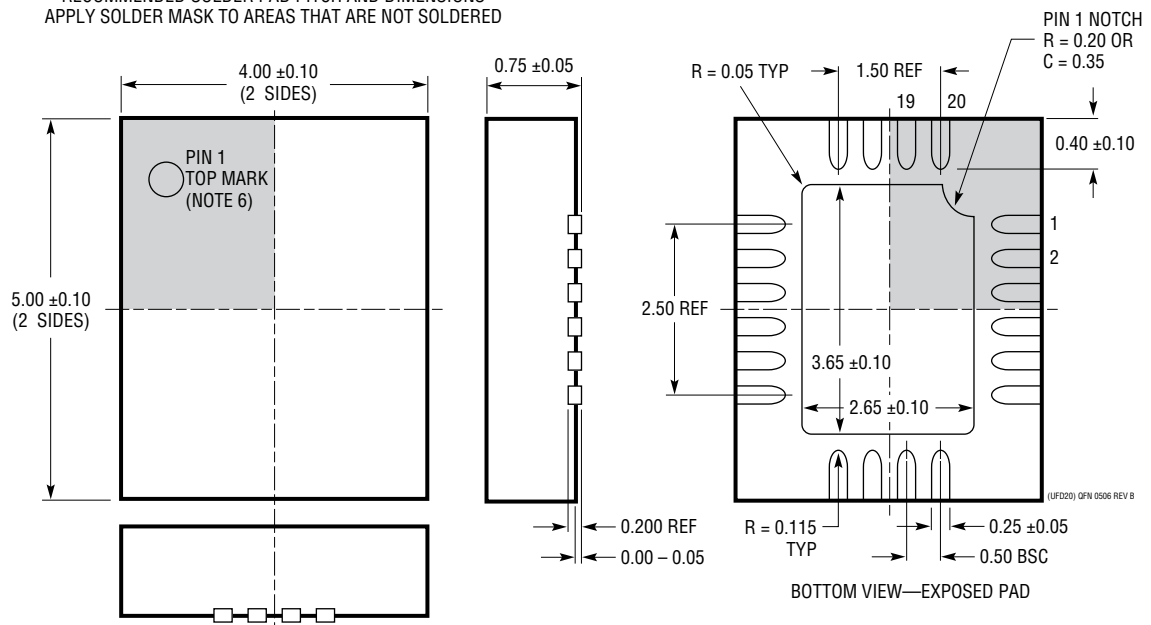

**NOTE:**

1. DRAWING PROPOSED TO BE MADE A JEDEC PACKAGE OUTLINE MO-220 VARIATION (WXXX-X).
2. DRAWING NOT TO SCALE
3. ALL DIMENSIONS ARE IN MILLIMETERS
4. DIMENSIONS OF EXPOSED PAD ON BOTTOM OF PACKAGE DO NOT INCLUDE MOLD FLASH. MOLD FLASH, IF PRESENT, SHALL NOT EXCEED 0.15mm ON ANY SIDE
5. EXPOSED PAD SHALL BE SOLDER PLATED
6. SHADED AREA IS ONLY A REFERENCE FOR PIN 1 LOCATION ON THE TOP AND BOTTOM OF PACKAGE

## TYPICAL APPLICATION

LTC4125 Driving a 24 $\mu$ H Transmit Coil at 103kHz, with 530mA Input Current Threshold, 119kHz Frequency Limit and 41.5 $^{\circ}$ C Transmit Coil Surface Temperature Limit in a Wireless Power System with LTC4120 as a 200mA Single Cell Li-Ion Battery Charger at the Receiver

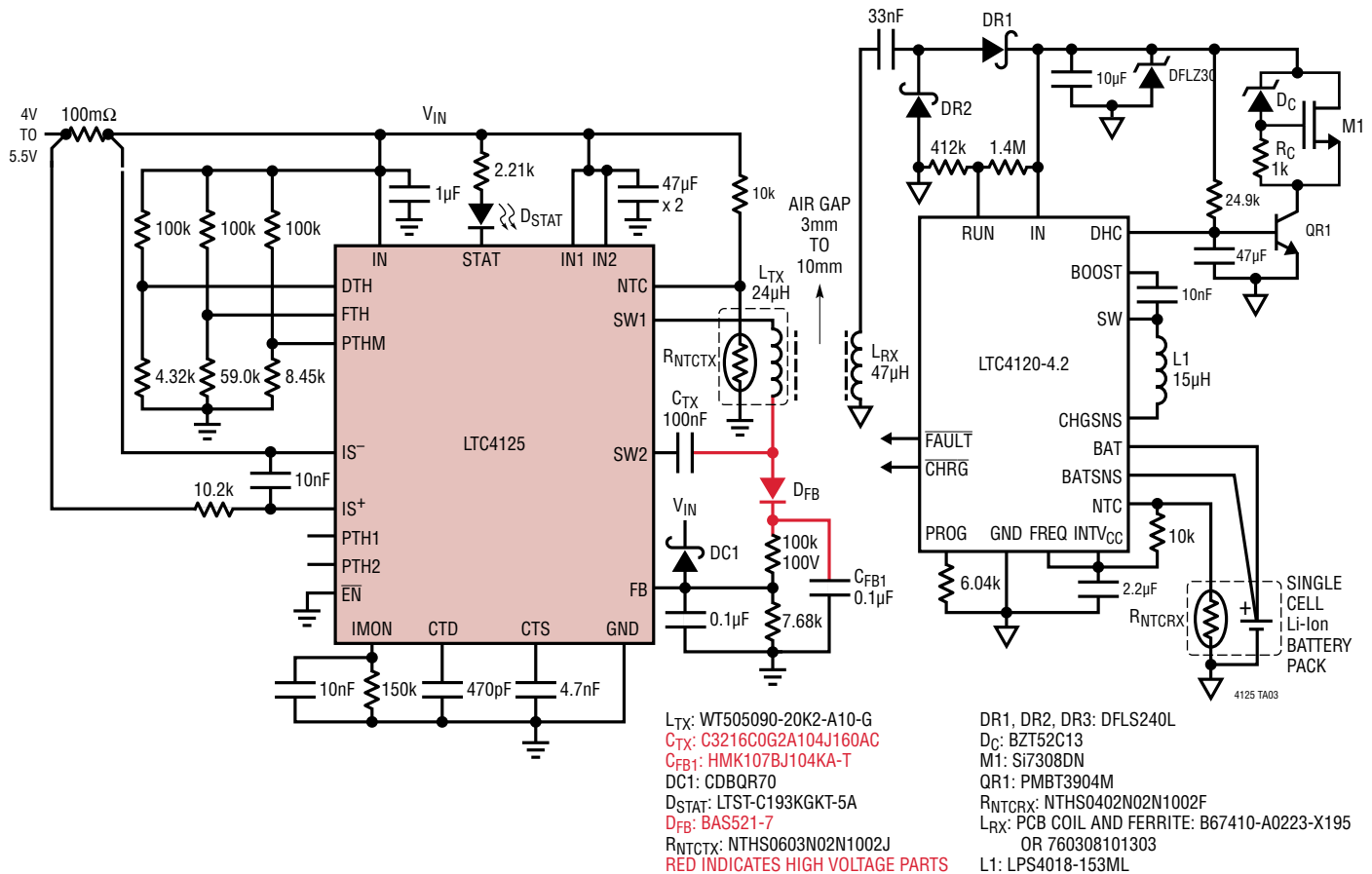

## RELATED PARTS

| PART NUMBER              | DESCRIPTION   | COMMENTS  |
|--------------------------|---|---|
| <a href="#">AN138</a>    | Wireless Power User Guide   |   |
| <a href="#">LTC4120</a>  | Wireless Power Receiver and 400mA Buck Battery Charger                  | Wireless 1 to 2 Cell Li-Ion Charger, 400mA Charge Current, Dynamic Harmonization Control, Wide Input Range: 12.5V to 40V, 3mm × 3mm QFN-16 Package.   |
| <a href="#">LTC4070</a>  | Li-Ion/Polymer Shunt Battery Charger System                             | Low Operating Current (450nA), 1% Float Voltage Accuracy Over Full Temperature and Shunt Current Range, 50mA Maximum Internal Shunt Current (500mA with External PFET), Pin Selectable Float Voltages: 4.0V, 4.1V, 4.2V. Ultralow Power Pulsed NTC Float Conditioning for Li-Ion/Polymer Protection, 8-Lead (2mm × 3mm) DFN and MSOP.   |
| <a href="#">LTC4071</a>  | Li-Ion/Polymer Shunt Battery Charger System with Low Battery Disconnect | Integrated Pack Protection, <10nA Low Battery Disconnect Protects Battery from Over-Discharge. Low Operating Current (550nA), 1% Float Voltage Accuracy Over Full Temperature and Shunt Current Range, 50mA Maximum Internal Shunt Current, Pin Selectable Float Voltages: 4.0V, 4.1V, 4.2V. Ultralow Power Pulsed NTC Float Conditioning for Li-Ion/Polymer Protection, 8-Lead (2mm × 3mm) DFN and MSOP. |
| <a href="#">LT3652HV</a> | Power Tracking 2A Battery Charger                                       | Input Supply Voltage Regulation Loop for Peak Power Tracking in (MPPT) Solar Applications Standalone, V <sub>IN</sub> : 4.95V to 34V (40V ABSMAX), 1MHz, 2A Charge Current, V <sub>OUT</sub> : 3.3V to 18V, Timer or C/10 Termination, 12-Lead 3mm × 3mm DFN and MSOP.  |